

No. GT-H12K/H30/H120K/HS30 Air Scissors

- Two types of blades, standard and micro-edge, are available.

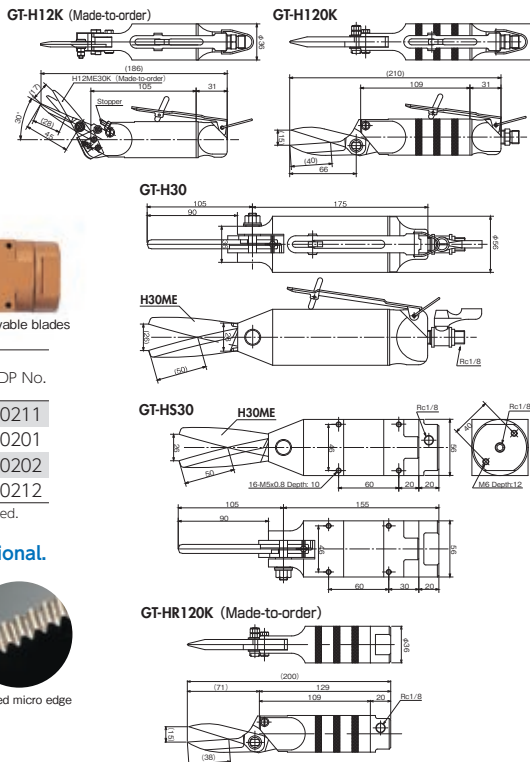
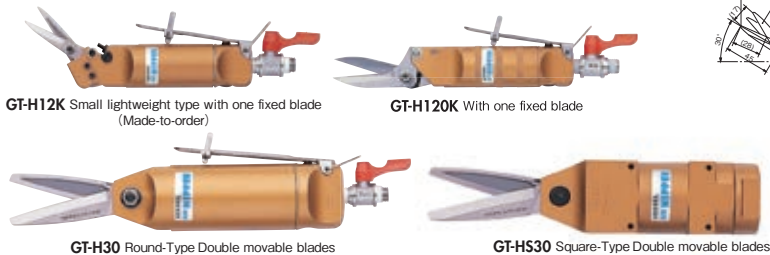

Model No.	Capacity (max) (mm)	Air Consumption (cm ³ /str.)	Applied Pressure (MPa)	Overall Length (with Blade) (mm)	Weight (with Blade) (g)	EDP No.
GT-H30	Kevlar t=1	584	0.3	280	1,030	360211
GT-H12K	Kevlar t=0.3	116	0.2	186.2	290	360201
GT-H120K	Band steel 15x0.5t	116	0.5~0.6	211	340	360202
GT-HS30	Kevlar t=1	584	0.3	260	970	360212

· Hose coupling: R1/4 (Body Rc1/8) · Air hose inner dia.: 5 mm · Overall length/Weight: Accessories not included.
 · Total length and weight of the GT-HS30 and HS30 are given with the H30ME blade mounted.

※Blades are optional.

Blades specifications

Model No.	Applicable Nippers	Blade Shape	Blade Aperture (mm)	Effective Blade Cutting Length (mm)	Weight (g)	EDP No.
H30ME	H30,	Scissors type	26	50	280	360311
H30MEL	HS30	Serrated micro edge	34	67	285	360312
H12ME30K	H12K	Scissors type	17	28	56	360301
H120SK	H120K	Scissors type	15	38	115	360302

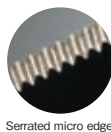

No. GT-HWR1/10 GT-HWS1/10 Double Action Air Scissors

- Blade opening and closing is driven by air piston.
- Having no spring mechanism in the main unit facilitates maintenance.



Model No.	Capacity φ (mm)		Air Consumption (cm ³ /str.)	Applied Pressure (N)	Air Pressure (MPa)	A (mm)	B (mm)	Weight (g)	EDP No.
	Copper	Steel							
Double Action Air Scissors (Round Type without Lever)									
GT-HWR1	1.0	0.5	45	294	0.4~0.5	95	20	84	360701
GT-HWR10	1.8	1.2	116	588	0.4~0.5	146	36	295	360714
Double Action Air Scissors (Square Type)									
GT-HWS1	1.0	0.5	45	294	0.4~0.5	95	23x20	116	360700
GT-HWS10	1.8	1.2	116	588	0.4~0.5	146	36	356	360713

※Blades are optional.

No. GT-NZ15/20 Air Nipper for Orchid Support Stick **NEW**

- Equipped with a cutting position stopper for prevention of mistakes in cutoff.
- Blade is with a urethane cover to hold the stick that was cut, not to let cut pieces from being scattered.

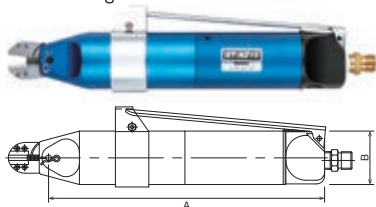

Model No.	Capacity		Air Consumption (cm ³ /str.)	Applied Pressure (N)	Air Pressure (MPa)	A (mm)	B (mm)	Weight (g)	EDP No.
	Annealing Wire	Vinyl Stick (Pipe)							
GT-NZ15(NZ15AJ)	#10(Thin)	φ4.2~6	250	1177	0.65	213.5	40	455	—
GT-NZ15(NZ20AJ)	#8(Thick)	φ4.2~6	250	1177	0.65	213.5	40	465	360758

GT-HWR



GT-HWS



Applicable Blade Specifications

Model No.	Blade Opening (mm)	Cutting blade effective (mm)	A (mm)	Weight (g)	EDP No.
For GT-HWR1/HWS1					
HW1J	3.0	17	25	16	360452
For GT-HWS10					
HW10J	5.0	28	40	76	360462

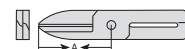

Note: The GT-NZ15/20 are designed for orchid support sticks available in Japan. This may not meet requirements in the overseas market. We don't have custom-made models for these nippers.



Applicable Blade Specifications

Model No.	Blade Opening (mm)	Cutting blade effective (mm)	A (mm)	Weight (g)	EDP No.
NZ15AJ	7.2	15	30	132	360504
NZ20AJ	7.5	15	31	142	360505