

11 Accessori

158 **NITTO KOHKI**

170 **SIRA**

173 **VESSEL**

184 **AIR MARTIN**

185 **IDTOOLS**

RACCORDI PER ARIA COMPRESSA

- Corpo in acciaio
- Guarnizioni in NBR

Pressione di esercizio

1.5 MPa (15 kgf/cm²)

1.0 MPa (10 kgf/cm²)

Struttura

Chiusura a singola direzione

Fluidi applicabili
(l'acciaio si applica solo con l'aria)

Aria

Acqua

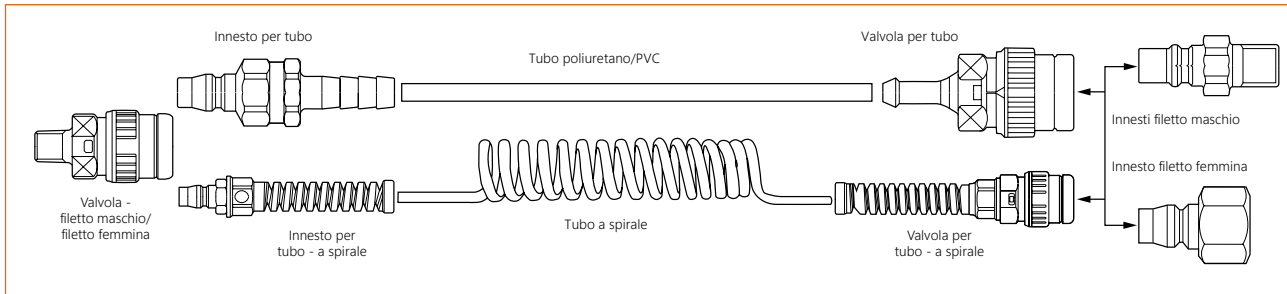
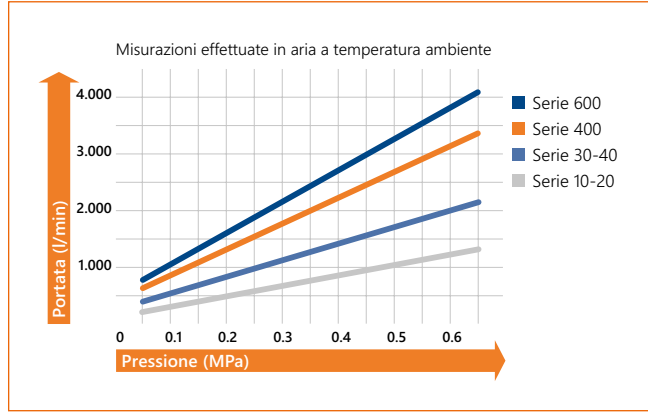
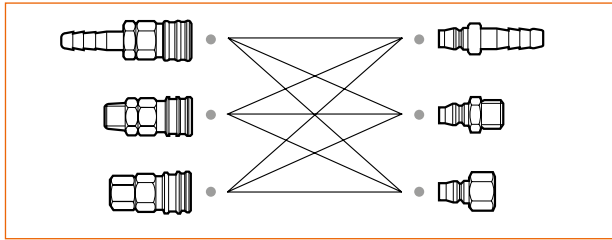

INNESTI

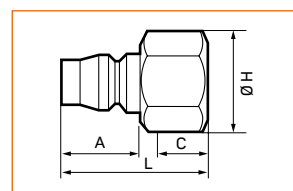
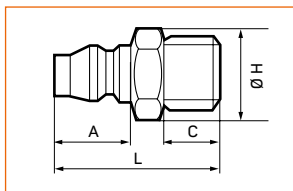

Con filetto maschio tipo PM

Modello	App.	Peso g	L. tot mm	Ø H mm	A mm	C mm
10PM	maschio 1/8"	22	37	Hex 14	20	10
20PM	maschio 1/4"	25	41	Hex 14	20	13
30PM	maschio 3/8"	46	42	Hex 19	20	14
40PM	maschio 1/2"	59	46	Hex 22	20	16

Con filetto femmina tipo PF

Modello	App.	Peso g	L. tot mm	Ø H mm	A mm	C mm
20PF	femmina 1/4"	28	36	Hex 17	20	13
30PF	femmina 3/8"	39	37	Hex 21	20	14
40PF	femmina 1/2"	70	38	Hex 29	20	15

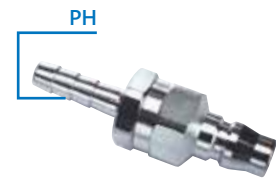
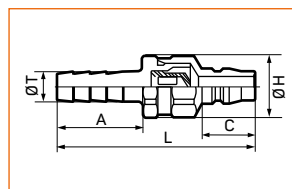
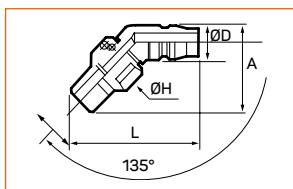

Girevole 360° con filetto maschio tipo PM

Modello	App.	Peso g	L. tot mm	Ø D mm	Ø H mm	A mm
RL-20PM	maschio 1/4"	52	52,1	14	Hex 19	34,1

Per tubo tipo PH (con scarico progressivo aria residua)

Modello	App.	Ø T mm	Peso g	L. tot mm	Ø H mm	A mm	C mm
PV-20PH	tubo 1/4"	9	59	70	Hex 23	28	20
PV-30PH	tubo 3/8"	11	62	74	Hex 23	32	20
PV-40PH	tubo 1/2"	15	76	77	Hex 23	35	20

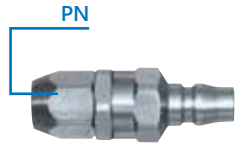
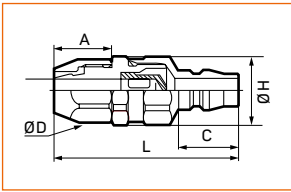

Per tubo in poliuretano tipo PN
(con scarico progressivo aria residua)

Modello	App. mm	Peso g	L. tot mm	Ø D mm	Ø H mm	A mm	C mm
PV-65PN	tubo 6,5x10	71	59	Hex 17	Hex 23	17	20
PV-85PN	tubo 8,5x12,5	78	61	Hex 19	Hex 23	19	20

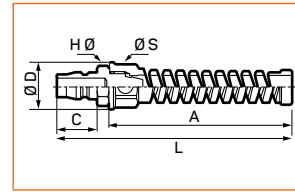

Per tubo in poliuretano tipo PNG

Modello	App. mm	Peso g	L. tot mm	Ø D mm	Ø H mm	Ø S mm	A mm	C mm
50PNG	tubo 5x8	41	116	23	Hex 17	Hex 19	90	20
65PNG	tubo 6,5x10	43	116	23	Hex 17	Hex 19	90	20
85PNG	tubo 8,5x12,5	55	116	26	Hex 19	Hex 22	90	20

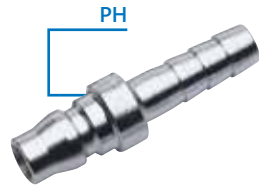
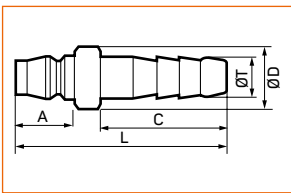

Per tubo tipo PH

Modello	App. mm	Ø T mm	Peso g	L. tot mm	Ø D mm	A mm	C mm
6MPH	tubo 6	8	25	55	16	20	30
8MPH	tubo 8	10	25	57	16	20	30
10MPH	tubo 10	12	30	57	16	20	30
12MPH	tubo 12	14	37	61	16	20	30
40PH	tubo 1/2"	15	53	63	20	20	36

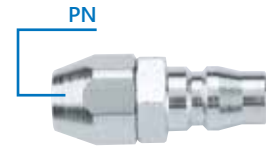
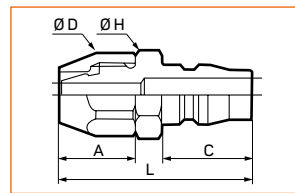

Per tubo in poliuretano tipo PN

Modello	App. mm	Peso g	L. tot mm	Ø H mm	Ø D mm	A mm	C mm
50PN	tubo 5x8	30	43	Hex 17	Hex 17	17	20
65PN	tubo 6,5x10	42	43	Hex 17	Hex 17	17	20
80PN	tubo 8x12	50	45	Hex 19	Hex 19	19	20
110PN	tubo 11x16	75	52	Hex 24	Hex 23	23	20

INNESTI SNODATI E NIPPLI SNODATI

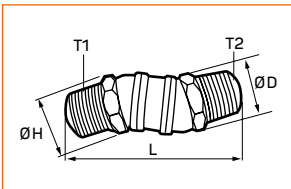

Filetto maschio/maschio (snodato: rotazione 360°/ snodo 45°)

Modello	Ø T1	Ø T2	L. tot mm	Ø D mm	Ø H mm
NFA-1M-1M	1/8"	1/8"	58	Hex 19	Hex 19
NFA-2M-2M	1/4"	1/4"	58	Hex 19	Hex 19
NFA-3M-3M	3/8"	3/8"	58	Hex 19	Hex 19

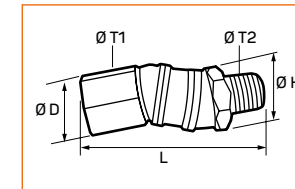

Filetto maschio/femmina (snodato: rotazione 360°/ snodo 45°)

Modello	Ø T1	Ø T2	L. tot mm	Ø D mm	Ø H mm
NFA-2F-2M	1/4"	1/4"	60	Hex 19	Hex 19
NFA-3F-3M	3/8"	3/8"	60	Hex 19	Hex 19

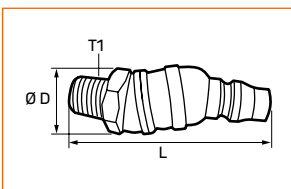

Filetto maschio/innesto Nitto Kohki
(snodato: rotazione 360°/ snodo 45°)

Modello	Ø T1	L. tot mm	Ø D mm
NFAP-2M	1/4"	63	Hex 19
NFAP-3M	3/8"	63	Hex 19



VALVOLE STANDARD

- Corpo in acciaio
- Guarnizioni in NBR
- Agganciamento rapido

Pressione di esercizio



1.5 MPa
{15 kgf/cm²}

Struttura



Chiusura a singola direzione

Fluidi applicabili



Aria

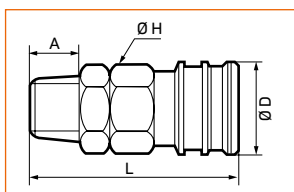
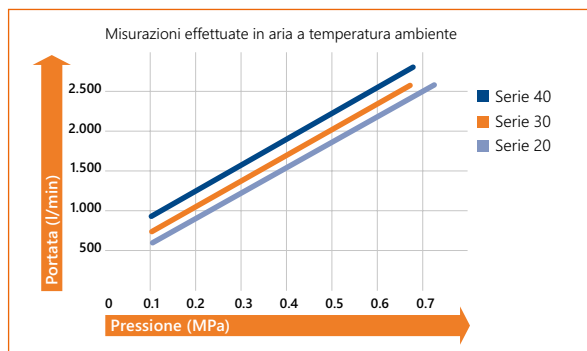

SM



Con filetto maschio tipo SM

Modello	App.	Peso g	L. tot mm	Ø D mm	Ø H mm	A mm
20SM	maschio 1/4"	101	55,5	26,5	Hex 19	13
30SM	maschio 3/8"	108	56,5	26,5	Hex 19	14
40SM	maschio 1/2"	131	59,5	26,5	Hex 22	16

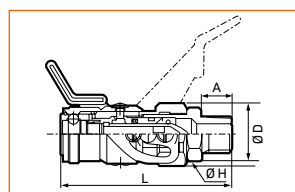

PV-SM



Con filetto maschio tipo SM

Modello	App.	Peso g	L. tot mm	Ø D mm	Ø H mm	A mm
PV-20SM	maschio 1/4"	225	79	29	Hex 22	13
PV-30SM	maschio 3/8"	229	80	29	Hex 22	14
PV-40SM	maschio 1/2"	235	82	29	Hex 22	16

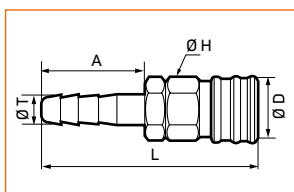

SH



Per tubo tipo SH

Modello	App. mm	Ø T	Peso g	L. tot mm	Ø D mm	Ø H mm	A mm
6MSH	tubo 6	8	95	72,5	26,5	Hex 19	30
8MSH	tubo 8	10	98	72,5	26,5	Hex 19	30
10MSH	tubo 10	12	101	72,5	26,5	Hex 19	30
12MSH	tubo 12	14	108	72,5	26,5	Hex 19	30
40SH	tubo 1/2"	15	118	78,5	26,5	Hex 19	36

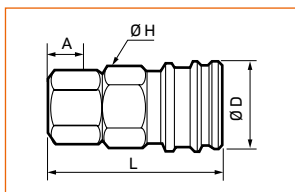

SF



Con filetto femmina tipo SF

Modello	App.	Peso g	L. tot mm	Ø D mm	Ø H mm	A mm
20SF	femmina 1/4"	95	49,5	26,5	Hex 19	13
30SF	femmina 3/8"	103	50,5	26,5	Hex 21	14
40SF	femmina 1/2"	139	52,5	26,5	Hex 29	15

VALVOLE "ONE TOUCH" SERIE 200

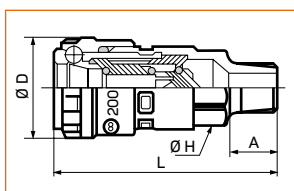

SM



Con filetto maschio tipo SM

Modello	App.	Peso g	L. tot mm	Ø D mm	Ø H mm	A mm
200-20SM	maschio 1/4"	89	60	26,6	Hex 19	14,5
200-30SM	maschio 3/8"	91	60,5	26,6	Hex 19	13
200-40SM	maschio 1/2"	102	56	26,6	Hex 24	16

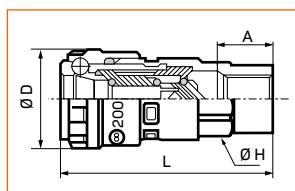

SF



Con filetto femmina tipo SF

Modello	App.	Peso g	L. tot mm	Ø D mm	Ø H mm	A mm
200-20SF	femmina 1/4"	94	57,5	26,6	Hex 19	14,5
200-30SF	femmina 3/8"	103	55,5	26,6	Hex 22	13
200-40SF	femmina 1/2"	138	57,5	26,6	Hex 29	16

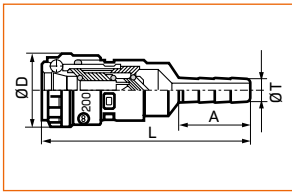

Per tubo tipo SH

Modello	App. mm	Ø T	Peso g	L. tot mm	Ø D mm	A mm
200-20SH	tubo 1/4"	9	90	77	26,6	27,5
200-30SH	tubo 3/8"	11	92	79	26,6	32
200-40SH	tubo 1/2"	15	104	79,5	26,6	32
200-6MSH	tubo Ø 6	8	86	71	26,6	20
200-8MSH	tubo Ø 8	10	90	76	26,6	25
200-10MSH	tubo Ø 10	12	93	78	26,6	34

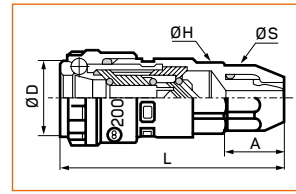

Per tubo in poliuretano tipo SN

Modello	App. mm	Peso g	L. tot mm	Ø D mm	Ø H mm	S mm	A mm
200-50SN	tubo 5x8	105	64,5	26,6	Hex 19	Hex 17	17
200-65SN	tubo 6,5x10	106	64,5	26,6	Hex 19	Hex 17	17
200-80SN	tubo 8x12	112	66,5	26,6	Hex 19	Hex 19	19
200-110SN	tubo 11x16	127	70,5	26,6	Hex 23	Hex 24	23

VALVOLE CON CHIUSURA DI SICUREZZA "ONE TOUCH" SERIE L-200A

- Corpo in acciaio
- Guarnizioni in NBR
- Agganciamento rapido
- Chiusura di sicurezza per evitare lo sgancio accidentale

Pressione di esercizio



Struttura



Fluidi applicabili

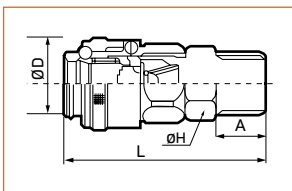
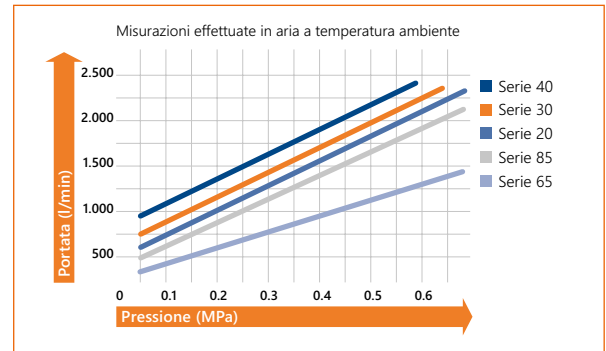

Con filetto maschio tipo SM

Modello	App.	Peso g	L. tot mm	Ø D mm	Ø H mm	A mm
L200A-20SM	maschio 1/4"	89	60	27,4	Hex 19	13
L200A-30SM	maschio 3/8"	91	60	27,4	Hex 19	14
L200A-40SM	maschio 1/2"	102	56	27,4	Hex 24	16

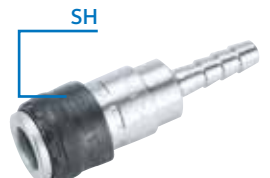
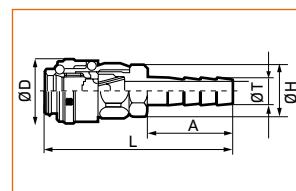

Per tubo tipo SH

Modello	App.	Ø T	Peso g	L. tot mm	Ø D mm	Ø H mm	A mm
L200A-20SH	tubo 1/4"	9	98	72,5	26,5	Hex 19	30
L200A-30SH	tubo 3/8"	11	102	76,5	26,5	Hex 19	34
L200A-40SH	tubo 1/2"	15	117	78,5	26,5	Hex 19	36

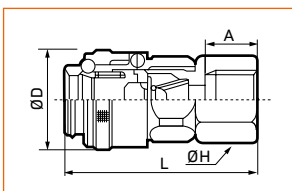

Con filetto femmina tipo SF

Modello	App.	Peso g	L. tot mm	Ø D mm	Ø H mm	A mm
L200A-20SF	femmina 1/4"	95	49,5	26,5	Hex 19	13
L200A-30SF	femmina 3/8"	96	50,5	26,5	Hex 21	14
L200A-40SF	femmina 1/2"	137	52,5	26,5	Hex 29	15



DISTRIBUTORI ROTANTI

- Corpo in acciaio
- Guarnizioni in NBR
- Temperatura di utilizzo: -5°C ~ +60°C
- Le valvole possono ruotare di 360°

Pressione di esercizio

1.5 MPa₂
{15 kgf/cm²}

Struttura

Chiusura a singola direzione

Fluidi applicabili

Aria

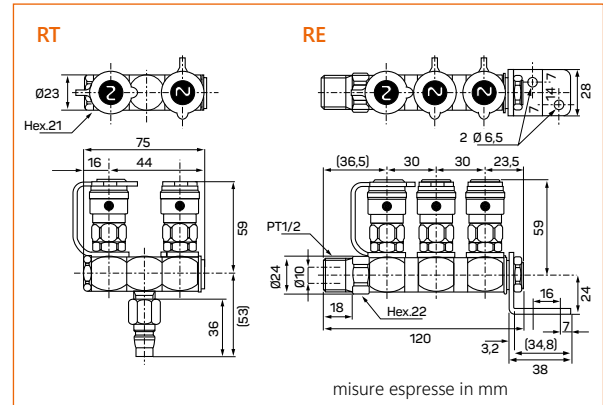
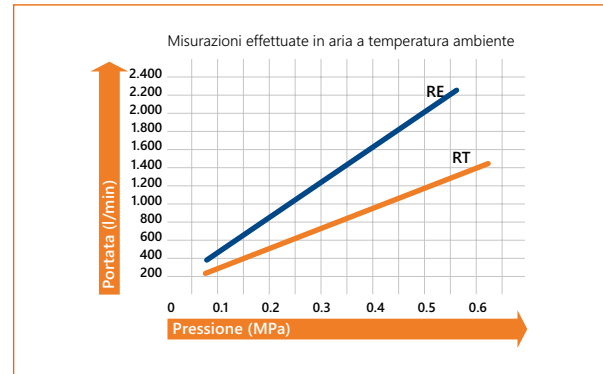
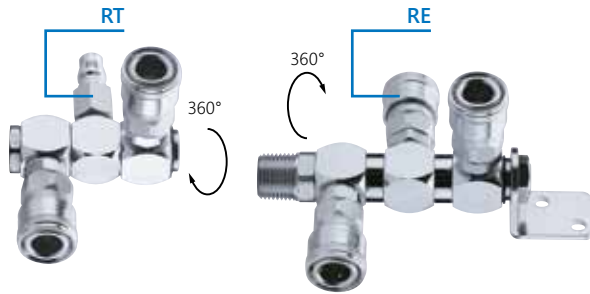

Modello	Ingresso aria	Uscita aria	Peso g
RT-NITTO	1 innesto (20PF)	2 valvole (Tipo 20)	460
RE-NITTO	1 foro 1/2" filettato maschio	3 valvole (Tipo 20)	630

RACCORDI SERIE JUMBO

INNESTI

Pressione di esercizio

1.5 MPa₂
{15 kgf/cm²}

1.0 MPa₂
{10 kgf/cm²}

Struttura

Chiusura a singola direzione

Fluidi applicabili
 (l'acciaio si applica solo con l'aria)

Aria

Acqua

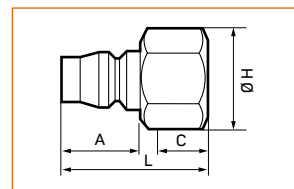
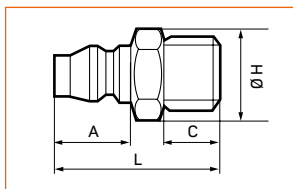

Con filetto maschio tipo PM

Modello	App.	Peso g	L. tot mm	Ø H mm	A mm	C mm
400PM	maschio 1/2"	69	50	Hex 22	23	16
600PM	maschio 3/4"	116	55	Hex 32	23	18

Con filetto femmina tipo PF

Modello	App.	Peso g	L. tot mm	Ø H mm	A mm	C mm
400PF	femmina 1/2"	82	41	Hex 29	23	15
600PF	femmina 3/4"	116	45	Hex 35	23	17

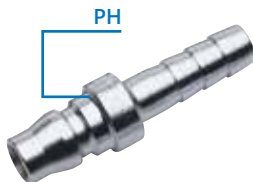
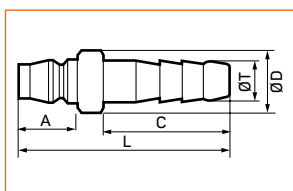

Per tubo tipo PH

Modello	App.	Ø T mm	L. tot mm	Ø H mm	A mm	C mm
400PH	tubo 1/2"	15	66	66	23	36
600PH	tubo 3/4"	21	121	77	23	45

VALVOLE

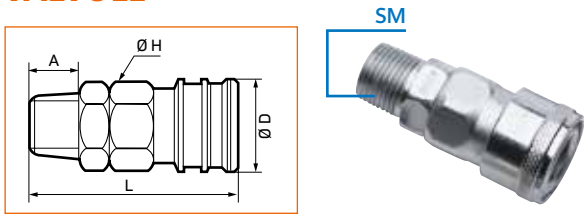

Con filetto maschio tipo SM

Modello	App.	Peso g	L. tot mm	Ø D mm	Ø H mm	A mm
400SM	maschio 1/2"	213	63	35	Hex 29	16
600SM	maschio 3/4"	260	67	35	Hex 32	19

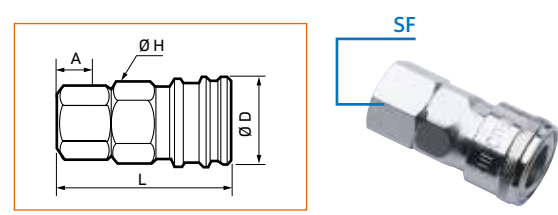

Con filetto femmina tipo SF

Modello	App.	Peso g	L. tot mm	Ø D mm	Ø H mm	A mm
400SF	femmina 1/2"	216	57	35	Hex 29	16
600SF	femmina 3/4"	260	61	35	Hex 35	19

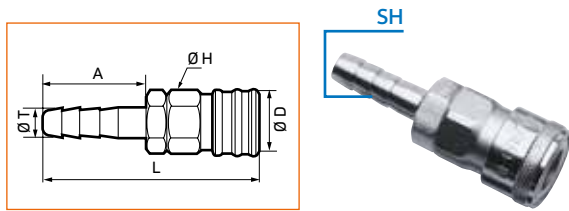

Per tubo tipo SH

Modello	App.	Ø T mm	L. tot mm	Ø D mm	Ø H mm	A mm
400SH	tubo 1/2"	15	83	35	29	36
600SH	tubo 3/4"	21	92	35	29	45

VALVOLE JUMBO CON CHIUSURA DI SICUREZZA E SCARICO ARIA RESIDUA PVR

- Corpo in acciaio
- Guarnizioni in NBR
- Ghiera di sicurezza per evitare lo sgancio accidentale

Pressione di esercizio

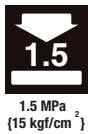

Struttura



Chiusura a singola direzione

Fluidi applicabili



Aria

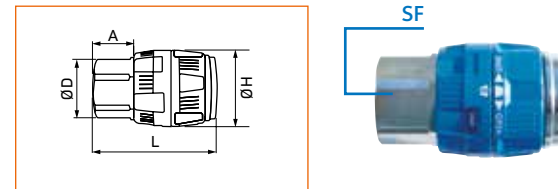

Con filetto femmina tipo SF

Modello	App.	Peso g	L. tot mm	Ø D mm	Ø H mm
PVR-400SF	femmina 1/2"	385	77	Hex 35	49
PVR-600SF	femmina 3/4"	385	77	Hex 35	49

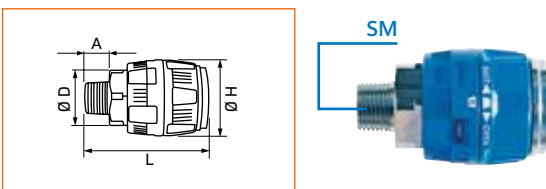

Con filetto maschio tipo SM

Modello	App.	Peso g	L. tot mm	Ø D mm	Ø H mm	A mm
PVR-400SM	maschio 1/2"	323	78	Hex 35	49	16
PVR-600SM	maschio 3/4"	323	78	Hex 35	49	16

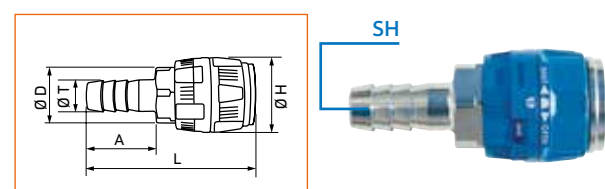

Per tubo tipo SH

Modello	App.	Ø T mm	Peso g	L. tot mm	Ø D mm	Ø H mm	A mm
PVR-400SH	tubo 1/2"	15	377	105	Hex 35	49	36
PVR-600SH	tubo 3/4"	21	377	105	Hex 35	49	36



RACCORDI IN RESINA "ONE TOUCH" SERIE PLA

- Ideali per il loro peso contenuto per tutte le applicazioni in cui il raccordo metallico può rovinare la superficie dei componenti / oggetti
- Corpo in materiale composito (BPT-POM)
- Guarnizioni in NBR
- Agganciamento rapido
- Chiusura di sicurezza per evitare lo sgancio accidentale
- Compatibili con tutte le altre serie di raccordi Nitto Kohki

Pressione di esercizio
1.5 MPa
 {15 kgf/cm²}

Struttura
Chiusura a singola direzione

Fluidi applicabili
Aria **Acqua**

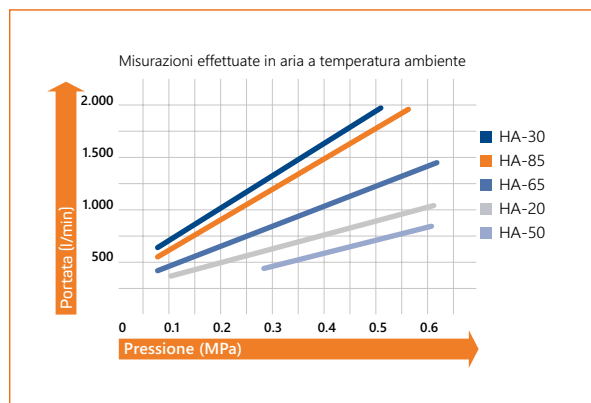

INNESTI

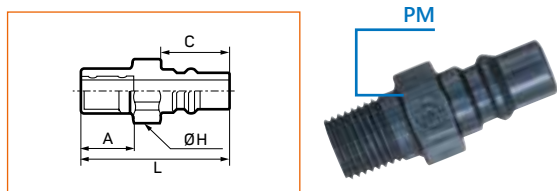

Con filetto maschio tipo PM

Modello	App.	Peso	L. tot	Ø H	A	C
		g	mm	mm	mm	mm
20PM-PLA	maschio 1/4"	8	43	Hex 17	15	20
30PM-PLA	maschio 3/8"	6	43	Hex 17	15	20

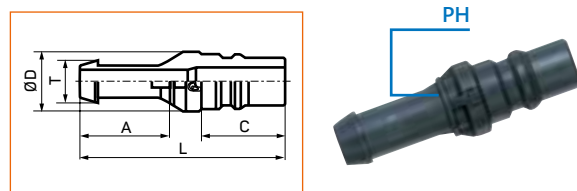

Per tubo tipo SH

Modello	App.	Ø T	Peso	L. tot	Ø D	A	C
		mm	g	mm	mm	mm	mm
20PH-PLA	tubo 1/4"	9	3	49	14	21,5	20
30PH-PLA	tubo 3/8"	11	4	52	16	23,5	20

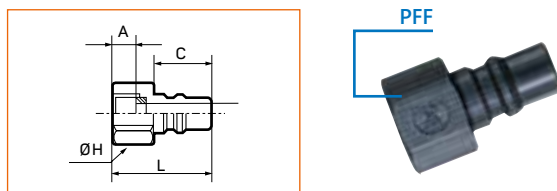

Con filetto femmina tipo PFF

Modello	App.	Peso	L. tot	Ø H	A	C
		g	mm	mm	mm	mm
20PFF-PLA	femmina 1/4"	6	34	Hex 19	8	20

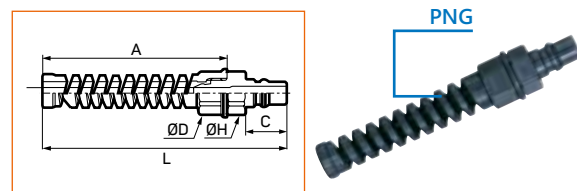

Per tubo in poliuretano tipo PNG

Modello	App.	Peso	L. tot	Ø D	Ø H	A	C
		g	mm	mm	mm	mm	mm
50PNG-PLA	tubo 5x8	9	119	Hex 19	Hex 19	90	20
65PNG-PLA	tubo 6,5x10	12	119	Hex 19	Hex 19	90	20
85PNG-PLA	tubo 8,5x12,5	16	119	Hex 22	Hex 19	90	20

VALVOLE

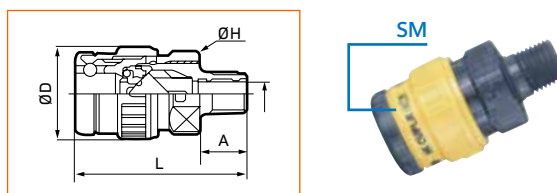

Con filetto maschio tipo SM

Modello	App.	Peso	L. tot	Ø D	Ø H	A
		g	mm	mm	mm	mm
HA-20SM	maschio 1/4"	27	55	30	Hex 24	15
HA-30SM	maschio 3/8"	26	55	30	Hex 24	15

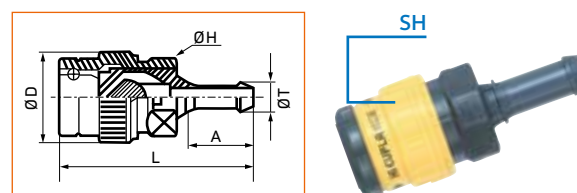

Per tubo tipo SH

Modello	App.	Ø T	Peso	L. tot	Ø D	Ø H	A
		mm	g	mm	mm	mm	mm
HA-20SH	tubo 1/4"	9	26	65,5	30	Hex 24	21,5
HA-30SH	tubo 3/8"	11	28	68	30	Hex 24	23,5

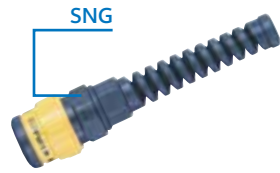
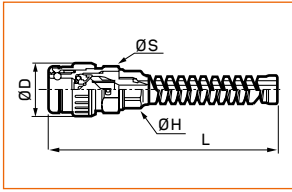

Per tubo in poliuretano tipo SNG

Modello	App. mm	Peso g	L. tot mm	Ø D mm	Ø S mm	Ø H mm
HA-50SNG	tubo 5x8	31	130	30	Hex 24	Hex 19
HA-65SNG	tubo 6,5x10	32	130	30	Hex 24	Hex 19
HA-85SNG	tubo 8,5x12,5	35	130	30	Hex 24	Hex 22

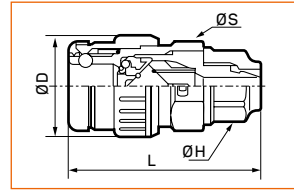

Per tubo in poliuretano tipo SN

Modello	App. mm	Peso g	L. tot mm	Ø D mm	Ø S mm	Ø H mm
HA-50SN	tubo 5x8	27	57	30	Hex 24	Hex 19
HA-65SN	tubo 6,5x10	27	57	30	Hex 24	Hex 19
HA-85SN	tubo 8,5x12,5	29	59,5	30	Hex 24	Hex 22



RACCORDI PASSAGGIO GAS INERTI E VUOTO SERIE SP-V

Chiusure automatiche sia su innesti che valvole. Ognuno di esse può sopportare un vuoto fino a $1,3 \times 10^{-1}$ (-1) Pa, anche quando scollegato.

- Utilizza valvole di intercettazione automatiche con struttura a tenuta stagna sia nella valvola che nell'innesto. Ideale per applicazioni sotto vuoto.
- La presenza di valvole di intercettazione automatica sia nella valvola che nell'innesto facilita la gestione dei fluidi. Adatto a un'ampia gamma di applicazioni di vuoto fino a $1,3 \times 10^{-1}$ Pa { 1×10^{-3} mmHg} anche quando è scollegato.
- Sono disponibili tre tipi di materiale di tenuta per adattarsi a qualsiasi linea di produzione diversificata per condizionatori d'aria, frigoriferi o simili.
- Può essere collegato a SP CUPLA tipo A e SP-V CUPLA.

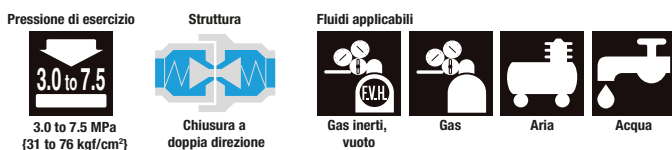

Materiale corpo	dimensione filettatura	Pressione di lavoro			
		MPa	kgf/cm ²	bar	PSI
In ottone (Materiale standard)	1/4", 3/8"	5.0	51	50	725
	1/2", 3/4"	3.0	31	30	435
Acciaio inox (materiale standard)	1/4", 3/8"	7.5	76	75	1090
Acciaio inox (articolo su ordinazione)	1/2", 3/4"	4.5	46	45	653

Materiale della guarnizione Campo di temperatura di lavoro			
MATERIALE DELLA GUARNIZIONE	Gomma in cloroprene	Gomma in fluoro	Gomma in idrogenato nitrilico
MARCHIO	CR	FKM	HNBR *2
RANGE TEMPERATURA DI LAVORO	-20°C to +80°C	-20°C to +180°C	-20°C to +120°C
RIFERIMENTI	Materiale standard	Materiale standard	Materiale standard

*1: L'intervallo di temperatura operativa dipende dalle condizioni di funzionamento.
 *2: Viene adottato l'HNBR che può essere utilizzato per applicazioni con olio refrigerante come l'HFC-134a.
 *2: Per i prodotti in materiale di tenuta HNBR non viene applicato grasso all'anello della valvola durante la spedizione. Assicurarsi di applicare l'olio per macchine frigorifere prima dell'uso.

DIREZIONE DI FLUSSO



INNESTO

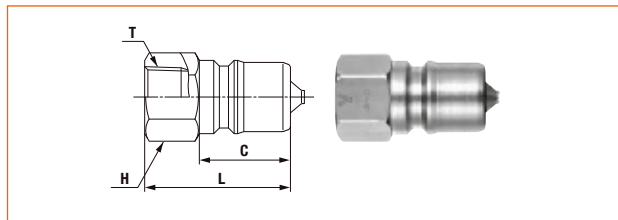

Modello	App.	Mass (g)		Dimensioni (mm)			
		brass	stainless	L	C	H (WAF)	T
2P-V-A	R 1/4	37	32	36	22	Hex. 17	Rc 1/4
3P-V-A	R 3/8	63	56	40	25	Hex. 21	Rc 3/8
4P-V-A*	R 1/2	118	109	44	28	Hex. 29	Rc 1/2
6P-V-A*	R 3/4	201	189	52	36	Hex. 35	Rc 3/4

VALVOLA

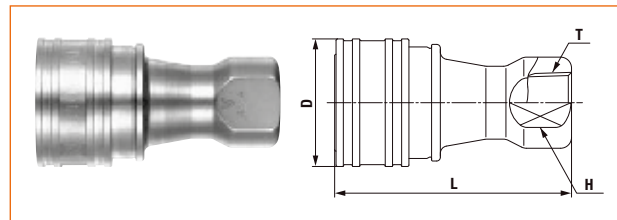

Modello	App.	Mass (g)		Dimensioni (mm)			
		brass	stainless	L	C	H (WAF)	T
2S-V-A	R 1/4	130	129	58	28	19	Rc 1/4
3S-V-A	R 3/8	202	192	65	35	21	Rc 3/8
4S-V-A*	R 1/2	396	388	72	45	29	Rc 1/2
6S-V-A*	R 3/4	680	644	88	55	35	Rc 3/4

RACCORDI PER TUBI IN OTTONE PER GAS INERTI E VUOTO SERIE PC-V

- Si aggancia direttamente ai tubi di rame dritti, eliminando inutili saldature o svasature.
- Resiste a un vuoto fino a $1,3 \times 10^{-1}$ Pa (quando è collegato), consentendo l'utilizzo nei test di tenuta, nell'aspirazione a vuoto e nella carica di refrigerante.
- Scegliete tra tre tipi di materiali di tenuta standard da utilizzare con i fluidi per le linee di produzione di condizionatori d'aria e frigoriferi. Molti modelli per adattarsi a tubi di varie dimensioni.
- L'utilizzo di una sola leva serra e sigilla simultaneamente il tubo.
- La struttura a doppia guarnizione, che aderisce perfettamente all'estremità e alla superficie esterna del tubo, garantisce un'eccellente tenuta e resistenza al vuoto.

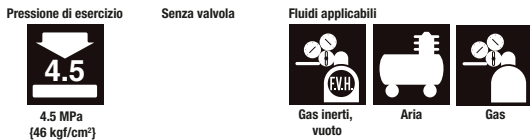

MODELLO	Tubo di rame OD mm	Materiale del corpo OD	Pressione di lavoro			
			MPa	kgf/cm ²	bar	PSI
PCV400	ø4.0	Ottone	4.5	46	45	653
PCV470	ø4.76 (3/16")	Ottone	4.5	46	45	653
PCV500	ø5.0	Ottone	4.5	46	45	653
PCV600	ø6.0	Ottone	4.5	46	45	653
PCV630	ø6.35 (1/4")	Ottone	4.5	46	45	653
PCV800	ø8.0 (5/16")	Ottone	4.5	46	45	653
PCV950	ø9.52 (9.52)	Ottone	4.5	46	45	653
PCV1000	ø10.0	Ottone	4.5	46	45	653
PCV1270	ø12.7 (1/2")	Ottone	4.5	46	45	653
PCV1590	ø15.88 (5/8")	Ottone	4.5	46	45	653

Materiale della guarnizione Campo di temperatura di lavoro

MATERIALE DELLA GUARNIZIONE	Gomma in cloroprene	Gomma in fluoro	Gomma in idrogenato nitrilico
MARCHIO	CR	FKM	HNBR *2
RANGE TEMPERATURA DI LAVORO	-20°C to +80°C	-20°C to +180°C	-20°C to +120°C
RIFERIMENTI	Materiale standard	Materiale standard	Materiale standard

* 1: L'intervallo di temperatura di esercizio dipende dalle condizioni operative.
 * 2: La gomma nitrilica idrogenata (HNBR) è colorata in blu per facilitarne il riconoscimento.
 * 3: L'HNBR può essere utilizzato per applicazioni con olio di refrigerazione e refrigeranti come l'HFC-134a.

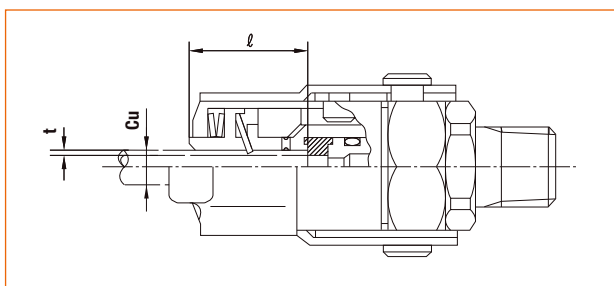

Gli articoli contrassegnati dall'asterisco (*) sono prodotti su ordinazione.

DIREZIONE DI FLUSSO

Il flusso del fluido può essere bidirezionale quando la presa e l'otturatore sono collegati.



PRODOTTO GRUPPO	Tubo OD (Cu)	Lungh. min. del tubo per l'inserimento (l)	Spessore min. del tubo (T)
PCV400*	ø4.0	-21	0.8 o più
PCV470w	ø4.76 (3/16")	-21	0.8 o più
PCV500*	ø5.0	-21	0.8 o più
PCV600	ø6.0	-21	0.8 o più
PCV630	ø6.35 (1/4")	-21	0.8 o più
PCV800	ø8.0 (5/16")	22.5	0.8 o più
PCV950	ø9.52 (3/8")	22.5	0.8 o più
PCV1000*	ø10.0	22.5	0.8 o più
PCV1270	ø12.7 (1/2")	32.5	1.0 o più
PCV1590	ø15.88 (5/8")	32.5	1.0 o più



DIMENSIONI

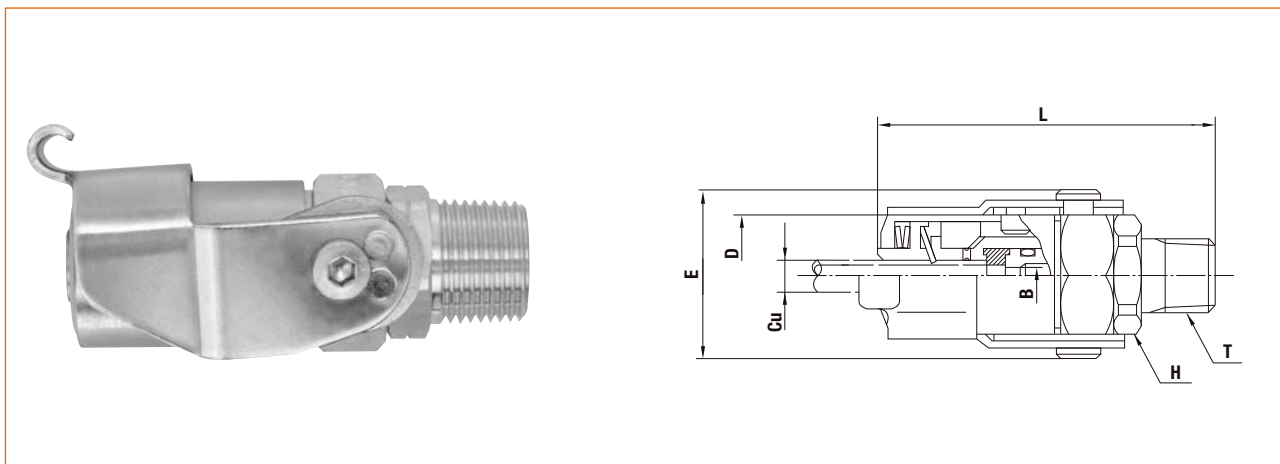

GRUPPO DI PRODOTTI	Tubo di rame OD mm	Modello	Applicazione (Filo)	Massa		Dimensioni (mm)				
				g	L	ØD	H (WAF)	ØB	E	T
PCV400*	ø4.0	PCV400-2	Rc 1/4	155	(59)	22.2	Hex.17	2.2	(32.5)	R 1/4
	ø4.0	PCV400-3	Rc 3/8	155	(60)	22.2	Hex.19	2.2	(32.5)	R 3/8
PCV470	ø4.76 (3/16")	PCV470-2	Rc 1/4	155	(60)	22.2	Hex.17	2.2	(32.5)	R 1/4
	ø4.76 (3/16")	PCV470-3	Rc 3/8	160	(61)	22.2	Hex.19	2.2	(32.5)	R 3/8
	ø4.76 (3/16")	PCV470-0	Innesto	160	(47)	22.2	-	-	(32.5)	-
PCV500*	ø5.0	PCV500-2	Rc 1/4	155	(59)	22.2	Hex.17	22.2	(32.5)	R 1/4
	ø5.0	PCV500-3	Rc 3/8	155	(60)	22.2	Hex.19	22.2	(32.5)	R 3/8
PCV600	ø6.0	PCV600-2	Rc 1/4	150	(60)	22.2	Hex.17	3.4	(32.5)	R 1/4
	ø6.0	PCV600-3	Rc 3/8	155	(61)	22.2	Hex.19	3.4	(32.5)	R 3/8
	ø6.0	PCV600-0	Innesto	155	(47)	22.2	-	-	(32.5)	-
PCV630	ø6.35 (1/4")	PCV630-2	Rc 1/4	145	(60)	22.2	Hex.17	3.4	(32.5)	R 1/4
	ø6.35 (1/4")	PCV630-3	Rc 3/8	150	(61)	22.2	Hex.19	3.4	(32.5)	R 3/8
	ø6.35 (1/4")	PCV630-0	Innesto	150	(47)	22.2	-	-	(32.5)	-
PCV800	ø8.0 (5/16")	PCV800-2	Rc 1/4	175	(62)	24.8	Hex.17	4.6	(35.5)	R 1/4
	ø8.0 (5/16")	PCV800-3	Rc 3/8	180	(63)	24.8	Hex.19	4.6	(35.5)	R 3/8
	ø8.0 (5/16")	PCV800-0	Innesto	185	(50)	24.8	-	-	(35.5)	-
PCV950	ø9.52 (3/8")	PCV950-2	Rc 1/4	175	(62)	24.8	Hex.17	4.6	(35.5)	R 1/4
	ø9.52 (3/8")	PCV950-3	Rc 3/8	180	(63)	24.8	Hex.19	4.6	(35.5)	R 3/8
	ø9.52 (3/8")	PCV950-0	Innesto	180	(50)	24.8	-	-	(35.5)	-
PCV1000*	ø10.0	PCV1000-2	Rc 1/4	155	(62)	24.8	Hex.17	4.6	(35.5)	R 1/4
	ø10.0	PCV1000-3	Rc 3/8	155	(63)	24.8	Hex.19	4.6	(35.5)	R 3/8
PCV1270	ø12.7 (1/2")	PCV1270-2	Rc 1/4	470	(80)	34.8	Hex.24	8.0	(45.0)	R 1/4
	ø12.7 (1/2")	PCV1270-3	Rc 3/8	465	(81)	34.8	Hex.24	9.7	(45.0)	R 3/8
	ø12.7 (1/2")	PCV1270-0	Innesto	475	(68)	34.8	-	-	(45.0)	-
PCV1590	ø15.88 (5/8")	PCV1590-2	Rc 1/4	424	(80)	34.8	Hex.24	8.0	(45.0)	R 1/4
	ø15.88 (5/8")	PCV1590-3	Rc 3/8	435	(81)	34.8	Hex.24	10.0	(45.0)	R 3/8
	ø15.88 (5/8")	PCV1590-0	Innesto	445	(68)	34.8	-	-	(45.0)	-

• Per la massa con tappo, aggiungere (corpo in ottone) 2P-V : 39 g, 3P-V : 67 g, (corpo in acciaio inox) 2P-V : 34 g, o 3P-V : 59 g
 * Disponibile su richiesta

PER L'OFFERTA COMPLETA DEI RACCORDI NITTO KOHKI VI PREGHIAMO DI CONTATTARE L'UFFICIO COMMERCIALE SIRA.

TUBI PER ARIA COMPRESSA

TUBI IN PVC RETINATO

- PVC rinforzato
- Temperatura di utilizzo: -15°C ~ +60°C

Modello	Ø Tubo mm
TUBO-NB6X11	6x11
TUBO-NB8X13	8x13
TUBO-NB10X15	10x15
TUBO-NB13X19	13x19
TUBO-NB16X23	16x23

fornito in rotoli da 50 m

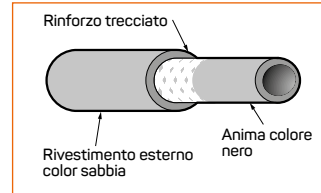

TUBI SOFT BLUE

- Pressione sopportata fino a 2 MPa (20 Bar)
- Temperatura di utilizzo: -15°C ~ +60°C

Modello	Ø Tubo mm
TN-6X11	6x11
TN-8X13	8x13
TN-9X15	9x15
TN-10X16	10x16
TN-12,7X19	12,7x19
TN-16X23 *	16x23
TN-19X26*	19x26
TN-25X33*	25x33

fornito in rotoli da 50 m (*25m)

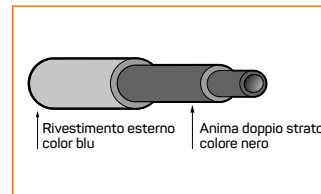

COLLARI STRINGITUBO

MODELLO	Ø Tubo mm	MODELLO	Ø Tubo mm
1007	5-7	1027	23-27
1009	7-9	1028	25-28
1011	9-11	1031	27-31
1013	11-13	1034	31-34
1015	13-15	1037	34-37
1018	15-18	1040	37-40
1020	17-20	1043	40-43
1023	20-23	1046	43-46
1025	22-25		

confezioni 100 pezzi



Collare stringitubo a due orecchie



Montaggio del collare stringitubo

TUBI A SPIRALE IN POLIURETANO, RACCORDATI

- Altissima qualità del materiale poliuretano con conseguente eccezionale capacità di "memoria" della spirale

MODELLO	Ø Tubo mm	lungh. utile mm	Raccordi
SI0500057	5x8	2.00	2x1/4" maschio
SI0500058	5x8	4.00	2x1/4" maschio
SI0500059	5x8	6.00	2x1/4" maschio
SI0500060	5x8	8.00	2x1/4" maschio
SI0500080	5x8	12.00	2x1/4" maschio
SI0500061	6,5x10	2.00	2x1/4" maschio
SI0500062	6,5x10	4.00	2x1/4" maschio
SI0500063	6,5x10	6.00	2x1/4" maschio
SI0500064	6,5x10	8.00	2x1/4" maschio
SI0500079	6,5x10	12.00	2x1/4" maschio
SI0500065	8x12	2.00	2x1/4" maschio
SI0500066	8x12	4.00	2x1/4" maschio
SI0500067	8x12	6.00	2x1/4" maschio
SI0500068	8x12	8.00	2x1/4" maschio
SI0500069	8x12	12.00	2x1/4" maschio
SI0500070	11x16	2.00	2x3/8" maschio
SI0500071	11x16	4.00	2x3/8" maschio
SI0500072	11x16	6.00	2x3/8" maschio
SI0500073	11x16	8.00	2x3/8" maschio
SI0500074	11x16	12.00	2x3/8" maschio

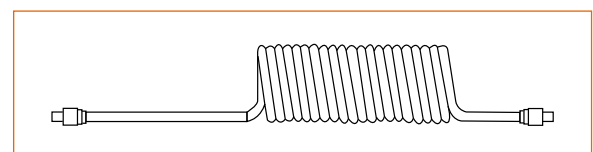

OLIO PER NEBULIZZATORI SIRA OIL CONFEZIONE 1L



REGOLATORE DI PORTATA

Modello	Attacchi filettati NPT
932-100-0	1/8"x1/8"
932-110-0	1/4"x1/4"

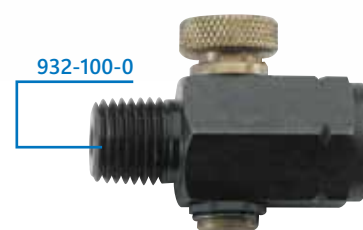

REGOLATORE DI PRESSIONE

- Pressione preimpostata in uscita a 0,6MPa (+/-10%) per incrementare la vita operativa degli utensili
- Pressione max in ingresso 1 Mpa
- Ideale per tutti gli utensili pneumatici con assorbimento < 1,3 m3/min

Modello	Peso g	Lunghezza mm	Ingresso	Uscita
SRPP6-14	0,1	61	1/4"	1/4"



BUSSOLE GUIDATE ANTIVIBRANTI

- Prolunghe serie AV (anti-vibration) appositamente studiate per l'utilizzo con avvitatori a massa battente idraulica
- Perfettamente guidate
- Eliminazione delle dispersioni di coppia
- Abbattimento del livello di vibrazioni
- Riduzione dell'usura dell'albero

MODELLO	Quadro femmina	Quadro maschio	Lunghezza mm	Tipo di intrattenimento
AV-350ENB	3/8"	3/8"	50	a sfera
AV-375ENB	3/8"	3/8"	75	a sfera
AV-310ENB	3/8"	3/8"	100	a sfera
AV-315ENB	3/8"	3/8"	150	a sfera
AV-320ENB	3/8"	3/8"	200	a sfera
AV-325ENB	3/8"	3/8"	250	a sfera
AV-330ENB	3/8"	3/8"	300	a sfera
AV-465ENB	1/2"	1/2"	65	a sfera
AV-475ENB	1/2"	1/2"	75	a sfera
AV-410ENB	1/2"	1/2"	100	a sfera
AV-415ENB	1/2"	1/2"	150	a sfera
AV-420ENB	1/2"	1/2"	200	a sfera
AV-425ENB	1/2"	1/2"	250	a sfera
AV-430ENB	1/2"	1/2"	300	a sfera
AV-685ENB	3/4"	3/4"	85	a sfera
AV-610ENB	3/4"	3/4"	100	a sfera
AV-615ENB	3/4"	3/4"	150	a sfera
AV-620ENB	3/4"	3/4"	200	a sfera
AV-625ENB	3/4"	3/4"	250	a sfera
AV-630ENB	3/4"	3/4"	300	a sfera
AV-304ANB	3/8"	1/2"	55	a sfera
AV-403ANB	1/2"	3/8"	55	a sfera
AV-406ANB	1/2"	3/4"	75	a sfera
AV-604ANB	3/4"	1/2"	60	a sfera
Mandrino a cambio rapido				
AV-DC3	3/8"	1/4" Hex	50	
AV-DC3-5/16	3/8"	5/16" Hex	50	
Avvitaprigionieri				
AV-306P1.0	3/8"	M6p1,0	50	
AV-308P1.25	3/8"	M8p1,25	50	
AV-310P1.25	3/8"	M10p1,25	50	
AV-310P1.5	3/8"	M10p1,5	50	
AV-410P1.25	1/2"	M10p1,25	60	
AV-410P1.5	1/2"	M10p1,5	60	

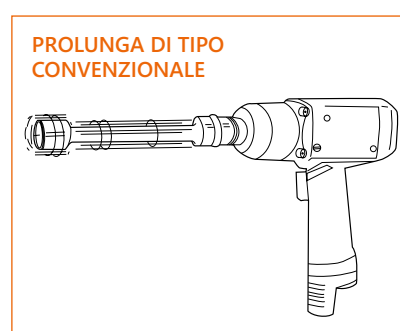
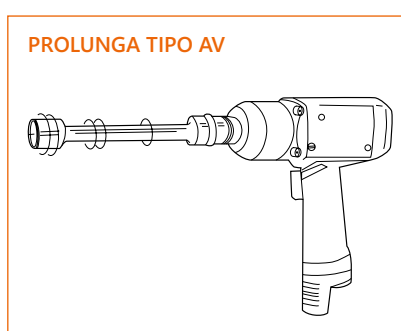
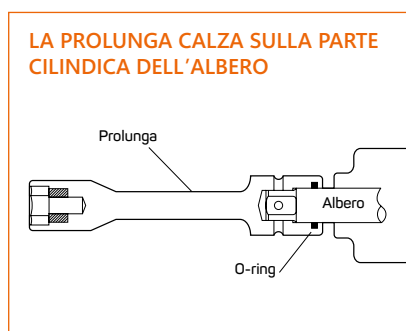

BILANCIATORI SIRAFLEX

IN MATERIALE COMPOSITO TIPO A

MODELLO	Portata Kg	Corsa fune mt	Peso Kg	Lunghezza mm	Larghezza mm	Spessore mm
SF.0-0,5	0-0,5	2,3	0,3	153	115	50
SF.0,5-1	0,5-1	2,3	0,35	153	115	50
SF.1-2	1-2	2,3	0,4	153	115	50
SF.2-3,5	2-3,5	2,3	0,4	153	115	50

TIPO B

MODELLO		Portata Kg	Corsa fune mt	Peso Kg	Lunghezza mm	Larghezza mm	Spessore mm
FLEX.0,5-1	Cavo in nylon	0,5-1	2,3	0,6	165	110	56
FLEX.0,5-1,5		0,5-1,5	2,3	0,6	165	110	56
FLEX.1-2		1-2	2,3	0,65	165	110	56
FLEX.2-3,5		2-3,5	2,3	0,65	165	110	56
FLEX.0,5-1A	Con cavo in acciaio	0,5-1	2,3	0,6	165	110	56
FLEX.0,5-1,5A		0,5-1,5	2,3	0,6	165	110	56
FLEX.1-2A		1-2	2,3	0,65	165	110	56
FLEX.2-3,5A		2-3,5	2,3	0,65	165	110	56
FLEX.3-6A		3-6	2,3	1,64	230	160	76
FLEX.5-8,5A		5-8,5	2,3	1,7	230	160	76
FLEX.8-11A		8-11	2,3	1,75	230	160	76

TIPO C

MODELLO	Portata Kg	Corsa fune mt	Peso Kg	Lunghezza mm	Larghezza mm	Spessore mm
FLEX-3C	1-3	1,7	1,4	290	148	69
FLEX-5C	3-5	1,7	1,5	290	148	69
FLEX-9C	5-9	1,6	3,4	340	174	136
FLEX-15C	9-15	1,6	3,8	340	174	136
FLEX-22	15-22	1,5	7,2	428	218	158
FLEX-30	22-30	1,5	8,5	428	218	158
FLEX-40	30-40	1,5	9,8	428	220	188
FLEX-50	40-50	1,5	10,4	428	220	188
FLEX-60	50-60	1,5	11,6	428	220	188
FLEX-70	60-70	1,5	11,8	428	220	188
FLEX-90	70-90	2,1	27	571	264	305,5
FLEX-105	85-105	2,1	29	571	264	305,5
FLEX-120	100-120	2,1	30	571	264	305,5

TIPO M

MODELLO	Portata Kg	Corsa fune mt	Peso Kg	Lunghezza mm	Larghezza mm	Spessore mm
MATIC-M.1,5	0,5-1,5	1,6	1,6	285	210	95
MATIC-M.3	1,5-3,0	1,6	1,7	285	210	95
MATIC-M.5	3,0-5,0	1,6	1,8	285	210	95



VESSEL BITS

La gamma qui presentata è solo una selezione dell'intero panorama di accessori di avvitatura VESSEL. Su richiesta, sono disponibili proposte specifiche alle svariate esigenze.

All'interno dei gruppi e delle famiglie di appartenenza, ogni singola lama è realizzata con:

- Un proprio trattamento termico specifico in grado di sviluppare il miglior rendimento operativo contestuale.
- Un'accurata selezione di elementi come Carbone, Silicio, Magnesio, Nickel, Cromo, Molibdeno e Vanadio, aggiunti a miscela all'acciaio di base, per disegnare le caratteristiche specifiche uniche.
- La precisione costruttiva è un bisogno imprescindibile: ogni singola lama è prodotta con elevati livelli di accuratezza e di controllo della qualità con costanti riferimenti alle norme internazionali ISO & JIS.

Sin dal 1954, la dedizione nello sviluppo e produzione dei bits industriali ha contemplato costanti aggiornamenti e miglioramenti tali da poter annoverare a tutt'oggi VESSEL come uno dei produttori mondiali di attrezzatura industriale di indiscussa eccellenza.

A richiesta su tutti i prodotti sono ottenibili trattamenti termici speciali in grado di conferire delle durezzae comprese tra i 53HRC ed i 62 HRC.

Per tutte le informazioni, non esitate a contattare i nostri addetti.

LEGENDA

V CC X LL TT 00 / dd X II

VESSEL	codice attacco	X	Lungh. mm	Tipo impronta	Dimens. impronta	/	Ribassamento sul diam.	X	Lungh. ribassamento
V	25	X	25	AF = BUSSOLA HEX	0		1,2		20
	61		33	H = BRUGOLA	0		1,4		25
	63		44	IP = TORX PLUS	0		2		30
	71		50	MAF = BUSSOLA HEX MAGNETICA	1		3		40
	73		64	MBH = PORTA INSERTI MAGNETICO	2		3,2		...
	76		70	N = PHILLIPS	3	
	...		75	P = POZIDRIV	4	
			90	SH = BRUGOLA TESTA SFERICA	5	
			100	SQ = IMPRONTA QUADRA	6	
			150	T = TORX	7	
			...	TH = TORX CON FORO
				TW = 3 WING		
				W = TAGLIO		
V	codice	x	mm	norma	codice	/	mm	x	mm

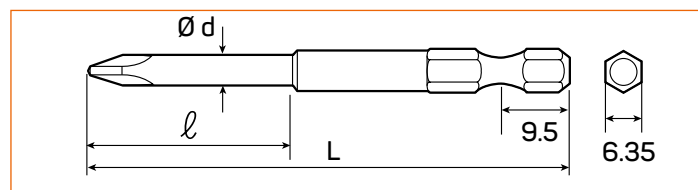

ATTACCO BAIONETTA 4 MM

D73

- Att. Baionetta 4mm
- Impronta PHILLIPS
- lama di precisione

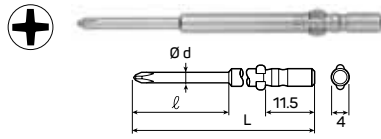

CODICE ART.	EDP No	PH	dφ	l	L	pezzi x conf.
V73X40N00/1,2	446001	0	1,2	20	40	10
V73X40N00	483001	0	1,5	20	40	10
V73X60N00	483002	0	1,5	20	60	10
V73X40N00/2	483005	0	2	20	40	10
V73X60N00/2	483006	0	2	20	60	10
V73X40N0/1,4	446016	0	1,4	20	40	10
V73X60N0/1,4	446017	0	1,4	20	60	10
V73X40N0/1,7	483010	0	1,7	20	40	10
V73X60N0/1,7	483011	0	1,7	20	60	10
V73X40N0	446025	0	2	20	40	10
V73X60N0	446026	0	2	20	60	10
V73X80N0	446027	0	2	20	80	10
V73X100N0	446028	0	2	20	100	10
V73X40N0/2,5	483015	0	2,5	20	40	10
V73X60N0/2,5	483016	0	2,5	20	60	10
V73X80N0/2,5	446033	0	2,5	20	80	10
V73X100N0/2,5	446034	0	2,5	20	100	10
V73X40N1	483021	1	3	20	40	10
V73X60N1	446053	1	3	20	60	10
V73X80N1	446054	1	3	20	80	10
V73X100N1	446055	1	3	20	100	10
V73X120N1	483376	1	3	20	120	10
V73X40N1/4	483025	1	4	-	40	10
V73X60N1/4	446059	1	4	-	60	10
V73X40N2	483031	2	4	-	40	10
V73X60N2	446070	2	4	-	60	10
V73X80N2	446071	2	4	-	80	10
V73X100N2	446072	2	4	-	100	10
V73X120N2	446073	2	4	-	120	10

D73

- Att. Baionetta 4mm
- Impronta TAGLIO
- lama di precisione

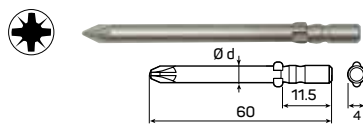

CODICE ART.	EDP No	PH	dφ	l	L	pezzi x conf.
V73X60P0	447414	0	4		60	10
V73X60P1	447415	1	4		60	10
V73X60P2	447430	2	4		60	10

D73

- Att. Baionetta 4mm
- Impronta BRUGOLA
- lama di precisione

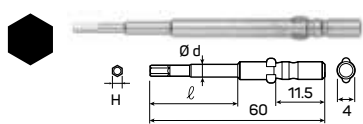

CODICE ART.	EDP No	PH	dφ	l	L	pezzi x conf.
V73X60H1,5	483051	1,5	2	20	60	10
V73X60H2	483052	2	3	20	60	10
V73X60H2,5	483053	2,5	3	20	60	10
V73X60H3	483054	3	4	-	60	10

D73

- Att. Baionetta 4mm
- Impronta TAGLIO
- lama di precisione

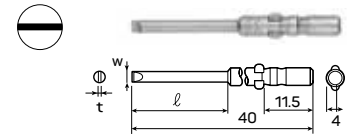

CODICE ART.	EDP No	W	t	l	L	pezzi x conf.
V73X40W1,3	446077	1,3	0,28	20	40	10
V73X40W1,7	446083	1,7	0,3	20	40	10
V73X40W2	483041	2	0,3	20	40	10
V73X40W2t0,4	446089	2	0,4	20	40	10
V73X40W2,5	483042	2,5	0,3	20	40	10
V73X40W2,5t0,4	446095	2,5	0,4	20	40	10
V73X40W3	446101	3	0,4	20	40	10
V73X40W4	483044	4	0,5	-	40	10

D73

- Att. Baionetta 4mm
- Impronta TORX
- Lama di precisione

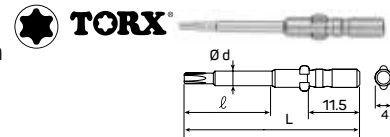

CODICE ART.	EDP No	T	dφ	l	L	pezzi x conf.
V73X40T1	635621	T1	1,5	20	40	10
V73X40T2	635622	T2	1,5	20	40	10
V73X40T3	635623	T3	1,7	20	40	10
V73X40T4	635624	T4	1,8	20	40	10
V73X40T5	446107	T5	2	20	40	10
V73X60T5	446108	T5	2	20	60	10
V73X40T6	446109	T6	2	20	40	10
V73X60T6	446110	T6	2	20	60	10
V73X60T7	446113	T7	2	20	60	10
V73X40T8	635628	T8	3	20	40	10
V73X60TH8	446116	T8H	4	-	60	10
V73X40T9	635629	T9	3	20	40	10
V73X40T10	635630	T10	3	20	40	10
V73X60TH10	446119	T10H	4	-	60	10

D73

- Att. Baionetta 4mm
- Impronta TORX PLUS
- lama di precisione

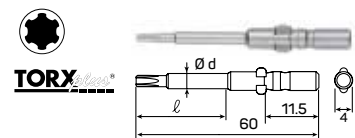

CODICE ART.	EDP No	IP	dφ	l	L	pezzi x conf.
V73X60IP4	447416	4IP	1,8	20	60	10
V73X60IP5	447417	5IP	2	20	60	10
V73X60IP6	447418	6IP	2,5	20	60	10
V73X60IP8	447419	8IP	3	20	60	10
V73X60IP10	447420	10IP	3	20	60	10

MEGADORA D73 BIT HOLDER



CODICE ART.	EDP No	Descrizione
910HD-73	122483	Megadora Bit Holder, D73 Ø 4mm Wing-shank

ATTACCO MEZZALUNA 4 MM

D71

- Att. mezzaluna 4mm
- Impronta PHILLIPS
- lama di precisione

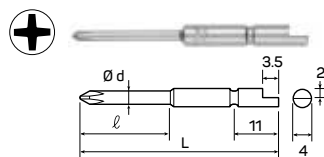

CODICE ART.	EDP No	PH	dφ	l	L	pezzi x conf.
V71X44N000	447433	0	1,5	20	44	10
V71X64N000	447464	0	1,5	20	64	10
V71X44N00	482901	0	1,5	20	44	10
V71X64N00	482902	0	1,5	20	64	10
V71X64N00/2	446293	0	2	20	64	10
V71X44N0	446290	0	1,8	20	44	10
V71X64N0	446291	0	1,8	20	64	10
V71X44N0/2	482911	0	2	20	44	10
V71X64N0/2	482912	0	2	20	64	10
V71X44N0/2,5	446294	0	2,5	20	44	10
V71X64N0/2,5	446295	0	2,5	20	64	10
V71X44N1	482921	1	3	20	44	10
V71X64N1	482922	1	3	20	64	10
V71X44N1/4	446298	1	4	20	44	10
V71X64N1/4	446299	1	4	20	64	10
V71X44N2	446300	2	4	20	44	10
V71X64N2	446301	2	4	20	64	10
V71X44N3	446302	3	6	20	44	10

D71

- Att. mezzaluna 4mm
- Impronta POZIDRIV
- lama di precisione

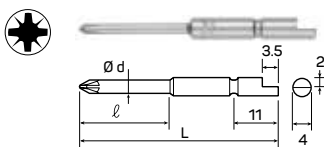

CODICE ART.	EDP No	PZ	dφ	l	L	pezzi x conf.
V71X44P0	447422	0	2,5	20	44	10
V71X64P0	447423	0	2,5	20	64	10
V71X44P1	447424	1	4	-	44	10
V71X64P1	447425	1	4	-	64	10

D71

- Att. mezzaluna 4mm
- Impronta BRUGOLA
- lama di precisione

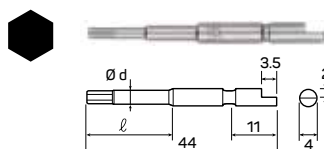

CODICE ART.	EDP No	H	dφ	l	L	pezzi x conf.
V71X44H1,5	446308	1,5	2	20	44	10
V71X44H2	446309	2	3	20	44	10
V71X44H2,5	446310	2,5	3	20	44	10
V71X44H3	446311	3	4	-	44	10

D71

- Att. mezzaluna 4mm
- BUSSOLA esagonale
- lama di precisione

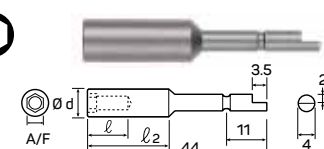

CODICE ART.	EDP No	A/F	dφ	l	L	pezzi x conf.
V71X44AF2,3	446312	2,3	4	20	44	10
V71X44AF2,5	446313	2,5	4	20	44	10
V71X44AF3	446314	3	5	20	44	10
V71X44AF4	446315	4	7	20	44	10
V71X44AF4,5	446316	4,5	7	20	44	10
V71X44AF5	446317	5	8	20	44	10
V71X44AF5,5	446318	5,5	8	20	44	10

D71

- Att. mezzaluna 4mm
- Impronta TAGLIO
- lama di precisione

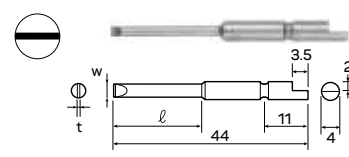

CODICE ART.	EDP No	W	t	l	L	pezzi x conf.
V71X44W2	446303	2	0,3	20	44	10
V71X44W2,5	446304	2,5	0,3	20	44	10
V71X44W3	446305	3	0,4	20	44	10
V71X44W4	446306	4	0,5	-	44	10
V71X44W5	446307	5	0,65	-	44	10

D71

- Att. mezzaluna 4mm
- Impronta TORX
- lama di precisione

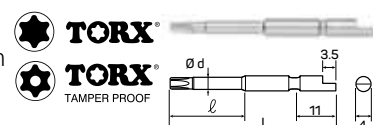

CODICE ART.	EDP No	T	dφ	l	L	pezzi x conf.
V71X44T1	635601	T1	1,5	20	44	10
V71X44T2	635602	T2	1,5	20	44	10
V71X44T3	635603	T3	1,7	20	44	10
V71X44T4	635604	T4	1,8	20	44	10
V71X44T5	446319	T5	2	20	44	10
V71X64T5	446320	T5	2	20	64	10
V71X44T6	446321	T6	2	20	44	10
V71X64T6	446322	T6	2	20	64	10
V71X44T7	635607	T7	2,5	20	44	10
V71X44T8	635608	T8	3	20	44	10
V71X44TH8	446323	T8H	3	20	44	10
V71X64TH8	446324	T8H	3	20	64	10
V71X44T9	635609	T9	3	20	44	10
V71X44TH10	446325	T10H	3	20	44	10
V71X64TH10	446326	T10H	3	20	64	10
V71X64TH15	446328	T15H	4	20	64	10
V71X64T20	447436	T20	3,8	20	64	10

D71

- Att. mezzaluna 4mm
- Impronta TORX PLUS
- lama di precisione

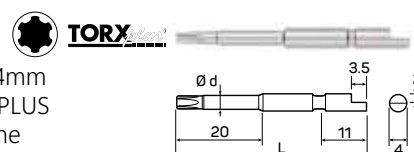

CODICE ART.	EDP No	IP	dφ	l	L	pezzi x conf.
V71X44IP2	447428	2IP	1,5	20	44	10
V71X64IP2	447412	2IP	1,5	20	64	10
V71X44IP3	447429	3IP	1,7	20	44	10
V71X64IP3	447413	3IP	1,7	20	64	10
V71X44IP4	447402	4IP	1,8	20	44	10
V71X64IP4	447403	4IP	1,8	20	64	10
V71X44IP5	447404	5IP	2	20	44	10
V71X64IP5	447405	5IP	2	20	64	10
V71X44IP6	447406	6IP	2,5	20	44	10
V71X64IP6	447407	6IP	2,5	20	64	10
V71X44IP8	447408	8IP	3	20	44	10
V71X64IP8	447409	8IP	3	20	64	10
V71X44IP10	447410	10IP	3	20	44	10
V71X64IP10	447411	10IP	3	20	64	10



ATTACCO 1/4" HEX - E6,3

B35

- 1/4" HEX - E6,3
- Impronta PHILLIPS
- Lama di precisione

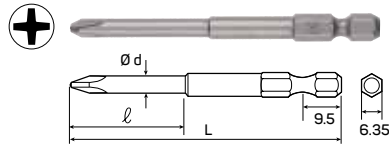

CODICE ART.	EDP No	PH	dφ	I	L	pezzi x conf.
V63X60N00/1,2X20	446126	0	1,2	20	60	10
V63X50N00/1,6X20	446423	0	1,58	20	49	10
V63X70N00/3,2	447347	0	3,17	-	70	10
V63X60N00/1,5X20	446128	0	1,5	20	60	10
V63X60N00/1,7X20	446130	0	1,7	20	60	10
V63X60N00/2X40	446139	0	2	40	60	10
V63X100N00/2X40	446141	0	2	40	100	10
V63X60N0/1,4X30	446145	0	1,4	30	60	10
V63X100N0/1,4X30	446147	0	1,4	30	100	10
V63X60N0/1,7X30	446150	0	1,7	30	60	10
V63X60N0/1,7X30	446151	0	1,7	40	80	10
V63X60N0/2X20	446153	0	2	20	60	10
V63X100N0/2X30	446157	0	2	30	100	10
V63X60N0/2,5X20	446159	0	2,5	20	60	10
V63X100N0/2,5X30	446163	0	2,5	30	100	10
V63X60N0/3X20	446165	0	3	20	60	10
V63X100N0/3X30	446169	0	3	30	100	10
V63X50N0/3,2X25	487195	0	3,17	25	49	10
V63X70N0/3,2	447348	0	3,17	25	70	10
V63X90N0/3,2	447349	0	3,17	25	89	10

B35

- 1/4" HEX - E6,3
- Impronta PHILLIPS
- Lama di potenza

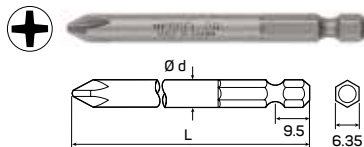

CODICE ART.	EDP No	PH	dφ	L	pezzi x conf.
V63X50N1	487200	1	4,76	49	10
V63X70N1	487201	1	4,76	70	10
V63X90N1	487202	1	4,76	89	10
V63X100N1/4,5	489254	1	4,5	100	10
V63X150N1/4,5	489672	1	4,5	150	10
V63X150N1	487203	1	4,76	152	10
V63X50N2/4,8	446424	2	4,76	49	10
V63X50N2	487205	2	6,35	49	10
V63X70N2	487206	2	6,35	70	10
V63X90N2	487207	2	6,35	89	10
V63X100N2/6	489255	2	6	100	10
V63X125N2/6	446435	2	6	127	10
V63X150N2/6	489673	2	6	150	10
V63X150N2	487208	2	6,35	152	10
V63X200N2/6	446439	2	6	200	10
V63X50N3/8	487210	3	7,9	49	10
V63X70N3/8	487211	3	7,9	70	10
V63X90N3/8	487212	3	7,9	89	10
V63X100N3/8	489256	3	8	100	10
V63X150N3/8	446437	3	8	150	10

B35

- 1/4" HEX - E6,3
- Impronta POZIDRIV
- Lama di precisione

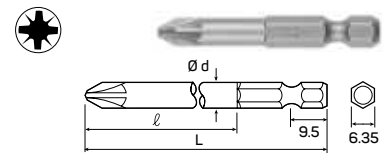

CODICE ART.	EDP No	PZ	dφ	I	L	pezzi x conf.
V63X60P0/1,4X30	447310	0	1,4	30	60	10
V63X100P0/1,4X30	447311	0	1,4	30	100	10
V63X60P0/1,7X30	447312	0	1,7	30	60	10
V63X80P0/1,7X40	447313	0	1,7	40	80	10
V63X60P0/2X20	447301	0	2	20	60	10
V63X100P0/2X30	447314	0	2	30	100	10
V63X60P0/2,5X20	447302	0	2,5	20	60	10
V63X100P0/2,5X30	447315	0	2,5	30	100	10
V63X60P0/3X20	447303	0	3	20	60	10
V63X100P0/3X30	447316	0	3	30	100	10

B35

- 1/4" HEX - E6,3
- Impronta POZIDRIV
- Lama di potenza

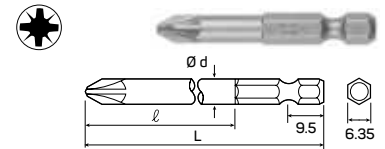

CODICE ART.	EDP No	PZ	dφ	I	L	pezzi x conf.
V63X70P0	447351	0	4,76		70	10
V63X100P1/4,5	489257	1	4,5		100	10
V63X50P1	487215	1	4,76		49	10
V63X70P1	487216	1	4,76		70	10
V63X90P1	487217	1	4,76		89	10
V63X150P1	487218	1	4,76		152	10
V63X100P2/6	489258	2	6		100	10
V63X125P2/6	446445	2	6		127	10
V63X150P2/6	489674	2	6		150	10
V63X200P2/6	446449	2	6		200	10
V63X50P2	487220	2	6,35		49	10
V63X70P2	487221	2	6,35		70	10
V63X90P2	487222	2	6,35		89	10
V63X150P2	487223	2	6,35		152	10
V63X50P3/8	487225	3	7,9		49	10
V63X70P3/8	487226	3	7,9		70	10
V63X90P3/8	487227	3	7,9		89	10
V63X100P3/8	489259	3	8		100	10
V63X50P4/8	489234	4	8		51	10
V63X75P4/8	489247	4	8		75	10



B35

- 1/4" HEX - E6,3
- BRUGOLA SFERICA
- Lama di potenza

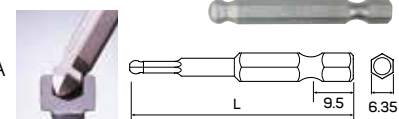

CODICE ART.	EDP No	SH	L	pezzi x conf.
V63X50SH2	446577	2	50	10
V63X50SH2,5	446578	2,5	50	10
V63X50SH3	446579	3	50	10
V63X50SH4	446580	4	50	10
V63X50SH5	446581	5	50	10
V63X50SH6	446582	6	50	10
V63X50SH8	446583	8	50	10

B35

- 1/4" HEX - E6,3
- Impronta BRUGOLA
- Lama di potenza

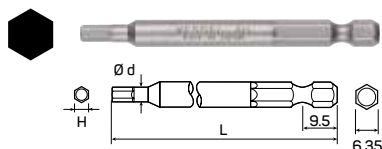

CODICE ART.	EDP No	H	dφ	L	pezzi x conf.
V63X75H2	424080	2	7	75	10
V63X100H2	424081	2	7	100	10
V63X150H2	424092	2	7	150	10
V63X50H2,5	487280	2,5		49	10
V63X75H2,5	424082	2,5	7	75	10
V63X100H2,5	424083	2,5	7	100	10
V63X150H2,5	424093	2,5	7	150	10
V63X50H3	487281	3	3,5	49	10
V63X75H3	424084	3	7	75	10
V63X100H3	424085	3	7	100	10
V63X150H3	424094	3	7	150	10
V63X50H4	487282	4	4,6	49	10
V63X75H4	424086	4	7	75	10
V63X100H4	424087	4	7	100	10
V63X150H4	424095	4	7	150	10
V63X50H5	487283	5	5,8	49	10
V63X75H5	424088	5	7	75	10
V63X100H5	424089	5	7	100	10
V63X150H5	424096	5	7	150	10
V63X50H6	487284	6		49	10
V63X75H6	424090	6	7	75	10
V63X100H6	424091	6	7	100	10
V63X150H6	424097	6	7	150	10
V63X70H7	489296	7	10	70	10
V63X50H8	447306	8		49	10
V63X70H8	489297	8	11	70	10
V63X150H8	424098	8		150	10
V63X70H9	489298	9	11	70	10
V63X70H10	489299	10	12	70	10
V63X150H10	424099	10	12	150	10
V63X50H10	447353	10		49	10
V63X50H6,35	487276	1/4"		49	10

MEGADORA B35 BIT HOLDER



CODICE ART.	EDP No	Descrizione
900W	122484	Megadora Bit Holder, E6.3

B35

- 1/4" HEX - E6,3
- Impronta TORX
- Lama di potenza

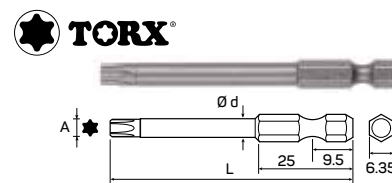

CODICE ART.	EDP No	T	A	L	pezzi x conf.
V63X50T5	446486	T5	1,37	49	10
V63X70T5	447355	T5	1,37	70	10
V63X50T6	446487	T6	1,65	49	10
V63X70T6	446498	T6	1,65	70	10
V63X90T6	447307	T6	1,65	89	10
V63X150T6	447317	T6	1,65	152	10
V63X50T7	446488	T7	1,99	49	10
V63X70T7	446499	T7	1,99	70	10
V63X90T7	446509	T7	1,99	89	10
V63X150T7	446519	T7	1,99	152	10
V63X50T8	446489	T8	2,31	49	10
V63X70T8	446500	T8	2,31	70	10
V63X90T8	446510	T8	2,31	90	10
V63X150T8	446520	T8	2,31	152	10
V63X50T9	446490	T9	2,5	49	10
V63X70T9	446501	T9	2,5	70	10
V63X90T9	446511	T9	2,5	90	10
V63X150T9	446521	T9	2,5	152	10
V63X50T10	446491	T10	2,74	49	10
V63X70T10	446502	T10	2,74	70	10
V63X90T10	446512	T10	2,74	90	10
V63X150T10	446522	T10	2,74	152	10
V63X50T15	446492	T15	3,27	49	10
V63X70T15	446503	T15	3,27	70	10
V63X90T15	446513	T15	3,27	90	10
V63X150T15	446523	T15	3,27	152	10
V63X50T20	446493	T20	3,86	49	10
V63X70T20	446504	T20	3,86	70	10
V63X90T20	446514	T20	3,86	90	10
V63X150T20	446524	T20	3,86	152	10
V63X50T25	446494	T25	4,43	49	10
V63X70T25	446505	T25	4,43	70	10
V63X90T25	446515	T25	4,43	90	10
V63X150T25	446525	T25	4,43	152	10
V63X50T27	446495	T27	4,99	49	10
V63X70T27	446506	T27	4,99	70	10
V63X90T27	446516	T27	4,99	90	10
V63X150T27	446526	T27	4,99	152	10
V63X50T30	446496	T30	5,52	49	10
V63X70T30	446507	T30	5,52	70	10
V63X90T30	446517	T30	5,52	90	10
V63X150T30	446527	T30	5,52	152	10
V63X50T40	446497	T40	6,65	49	10
V63X70T40	446508	T40	6,65	70	10
V63X90T40	446518	T40	6,65	90	10
V63X150T40	446528	T40	6,65	152	10



VESSEL

B35

- 1/4" HEX - E6,3
- Impronta TORX / FORO
- Lama di potenza

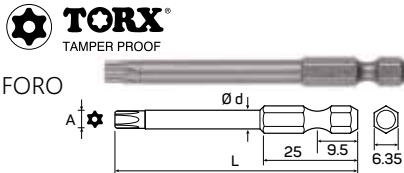

CODICE ART.	EDP No	T	A	L	pezzi x conf.
V63X50TH10	446533	T10H	2,74	49	10
V63X70TH10	446544	T10H	2,74	70	10
V63X90TH10	446556	T10H	2,74	90	10
V63X50TH20	446535	T20H	3,86	49	10
V63X70TH20	446546	T20H	3,86	70	10
V63X150TH20	446566	T20H	3,86	152	10

B35

- 1/4" HEX - E6,3
- Impronta TORX PLUS
- Lama di potenza

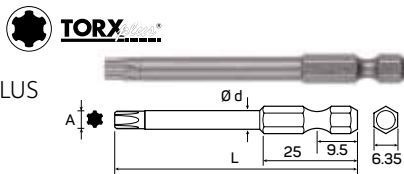

CODICE ART.	EDP No	IP	A	L	pezzi x conf.
V63X50IP5	447209	5IP	1,41	49	10
V63X70IP5	447210	5IP	1,41	70	10
V63X50IP6	447211	6IP	1,64	49	10
V63X70IP6	447212	6IP	1,64	70	10
V63X90IP6	447213	6IP	1,64	90	10
V63X150IP6	447251	6IP	1,64	152	10
V63X50IP7	447215	7IP	1,99	49	10
V63X70IP7	447216	7IP	1,99	70	10
V63X90IP7	447217	7IP	1,99	90	10
V63X150IP7	447252	7IP	1,99	152	10
V63X50IP8	447219	8IP	2,31	49	10
V63X70IP8	447220	8IP	2,31	70	10
V63X90IP8	447221	8IP	2,31	90	10
V63X150IP8	447253	8IP	2,31	152	10
V63X50IP9	447229	9IP	2,5	49	10
V63X70IP9	447236	9IP	2,5	70	10
V63X90IP9	447243	9IP	2,5	90	10
V63X150IP9	447226	9IP	2,5	152	10
V63X50IP10	447227	10IP	2,74	49	10
V63X70IP10	447228	10IP	2,74	70	10
V63X90IP10	447244	10IP	2,74	90	10
V63X150IP10	447254	10IP	2,74	152	10
V63X50IP15	447230	15IP	3,27	49	10
V63X70IP15	447237	15IP	3,27	70	10
V63X90IP15	447245	15IP	3,27	90	10
V63X150IP15	447255	15IP	3,27	152	10
V63X50IP20	447231	20IP	3,86	49	10
V63X70IP20	447238	20IP	3,86	70	10
V63X90IP20	447246	20IP	3,86	90	10
V63X150IP20	447256	20IP	3,86	152	10
V63X50IP25	447232	25IP	4,43	49	10
V63X70IP25	447239	25IP	4,43	70	10
V63X90IP25	447247	25IP	4,43	90	10
V63X150IP25	447257	25IP	4,43	152	10
V63X50IP27	447233	27IP	4,99	49	10
V63X70IP27	447240	27IP	4,99	70	10
V63X90IP27	447248	27IP	4,99	90	10
V63X150IP27	447258	27IP	4,99	152	10
V63X50IP30	447234	30IP	5,52	49	10
V63X70IP30	447241	30IP	5,52	70	10
V63X90IP30	447249	30IP	5,52	90	10
V63X150IP30	447259	30IP	5,52	152	10
V63X50IP40	447235	40IP	6,65	49	10
V63X70IP40	447242	40IP	6,65	70	10
V63X90IP40	447250	40IP	6,65	90	10
V63X150IP40	447260	40IP	6,65	152	10

B35

- 1/4" HEX - E6,3
- Impronta QUADRA
- Lama di potenza

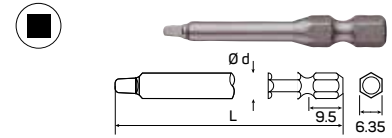

CODICE ART.	EDP No	SQ	L	pezzi x conf.
V63X70SQ1	487301	1 (3/32")	70	10
V63X70SQ2	487306	2 (1/8")	70	10
V63X70SQ3	487311	3 (9/64")	70	10

B35

- 1/4" HEX - E6,3
- Impronta 3 WING
- Lama di potenza

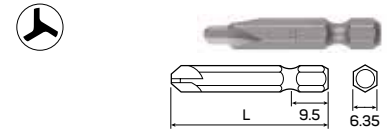

CODICE ART.	EDP No	TW	L	pezzi x conf.
V63X40TW2	424202	TW2	40	10
V63X40TW3	424203	TW3	40	10
V63X40TW4	424204	TW4	40	10
V63X40TW5	424205	TW5	40	10
V63X45TW6	424206	TW6	45	10
V63X45TW7	424207	TW7	45	10

B35

- 1/4" HEX - E6,3
- Impronta TAGLIO
- Lama di potenza

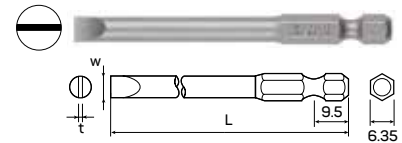

CODICE ART.	EDP No	W	t	L	pezzi x conf.
V63X50W3	489271	3	0,5	51	10
V63X50W3,1	446450	3,1	0,56	49	10
V63X75W3,1	446457	3,1	0,56	76	10
V63X100W3,1	446471	3,1	0,56	102	10
V63X50W3,4	446451	3,4	0,66	49	10
V63X70W3,4	446454	3,4	0,66	70	10
V63X50W3,8	446452	3,8	0,55	49	10
V63X100W3,8	446473	3,8	0,55	102	10
V63X50W4	489273	4	0,6	51	10
V63X50W4,8	487230	4,75	0,86	49	10
V63X70W4,8	446460	4,75	0,86	76	10
V63X100W4,8	446474	4,75	0,86	102	10
V63X50W5,5	487235	5,46	0,86	49	10
V63X75W5,5	446463	5,46	0,86	76	10
V63X50W5,5	489276	5,5	0,8	51	10
V63X50W6,3	487240	6,35	0,91	49	10
V63X100W6,3	446477	6,35	0,96	102	10
V63X50W7	487250	6,98	0,96	49	10
V63X50W7,9	487255	7,9	1,067	49	10
V63X75W7,9	446465	7,9	1,067	76	10
V63X50W9,1	487260	9,1	1,17	49	10
V63X75W9,1	446466	9,1	1,17	76	10
V63X100W9,1	446480	9,1	1,27	102	10

B35

- 1/4" HEX - E6,3
- Impronta TAGLIO
- guidalama integrato

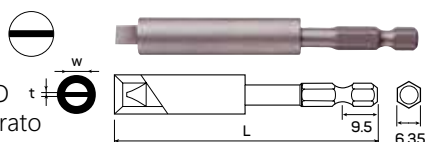

CODICE ART.	EDP No	W	t	screw head	L	pezzi x conf.
V600X95W4,9	489385	4,9	0,91	4~5	95	10
V600X95W5,5	487360	5,46	0,91	5~6	95	10
V600X95W6,1	487361	6,12	0,97	6~8	95	10
V600X95W7,4	487362	7,37	1,07	8~10	95	10
V600X95W8,9	487363	8,89	1,17	10~12	95	10
V600X95W10	487364	10,03	1,27	12~14	98	10

B35

- 1/4" HEX - E6,3
- BUSSOLA Esagonale
- Lama di potenza

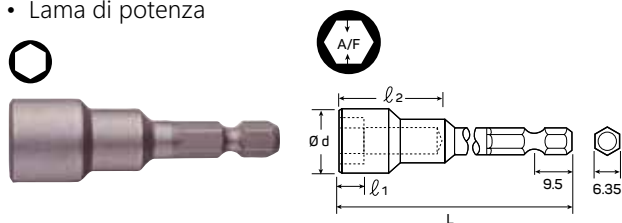

CODICE ART.	EDP No	A/F	D	l2	L	pezzi x conf.
V63X50AF4	489301	4	8	15	50	10
V63X75AF4	489314	4	8	25	75	10
V63X100AF4	489327	4	8	25	100	10
V63X50AF4,5	489302	4,5	8	15	50	10
V63X75AF4,5	489315	4,5	8	25	75	10
V63X50AF5	489303	5	8,5	15	50	10
V63X75AF5	489316	5	8,5	25	75	10
V63X150AF5	446602	5	8,5	25	150	10
V63X50AF5,5	489304	5,5	9	15	50	10
V63X75AF5,5	489317	5,5	9	25	75	10
V63X150AF5,5	446603	5,5	9	25	150	10
V63X50AF6	489305	6	10	15	50	10
V63X75AF6	489318	6	10	25	75	10
V63X150AF6	446604	6	10	25	150	10
V63X50AF7	489306	7	13	15	50	10
V63X75AF7	489319	7	13	25	75	10
V63X150AF7	446605	7	13	25	150	10
V63X50AF8	489307	8	13	15	50	10
V63X75AF8	489320	8	13	30	75	10
V63X150AF8	446606	8	13	30	150	10
V63X50AF9	489308	9	14	15	50	10
V63X75AF9	489321	9	14	30	75	10
V63X50AF10	489309	10	16	15	50	10
V63X75AF10	489322	10	16	30	75	10
V63X150AF10	446607	10	16	30	150	10
V63X50AF11	489310	11	17	15	50	10
V63X100AF11	489336	11	17	30	100	10
V63X50AF12	489311	12	18	15	50	10
V63X75AF12	489324	12	18	30	75	10
V63X150AF12	446608	12	18	30	150	10
V63X50AF13	489312	13	19	15	50	10
V63X75AF13	489325	13	19	30	75	10
V63X150AF13	446609	13	19	30	150	10
V63X50AF14	489313	14	20	15	50	10
V63X75AF14	489326	14	20	30	75	10
V63X150AF14	489339	14	20	30	100	10

B35

- 1/4" HEX - E6,3
- BUSSOLA Esagonale
- Lama di potenza
- MAGNETICO

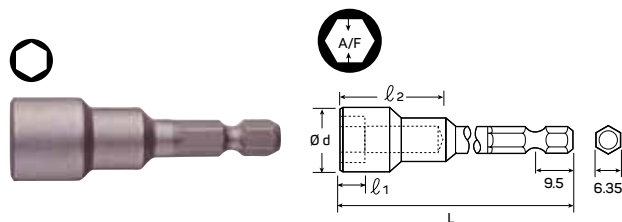

CODICE ART.	EDP No	A/F	D	l1	L	pezzi x conf.
V63X50MAF5	489340	5	8,5	3,5	50	10
V63X75MAF5	489351	5	8,5	3,5	75	10
V63X150MAF5	446619	5	8,5	3,5	150	10
V63X50MAF5,5	489341	5,5	9	3,5	50	10
V63X75MAF5,5	489352	5,5	9	3,5	75	10
V63X150MAF5,5	446620	5,5	9	3,5	150	10
V63X50MAF6	489342	6	10	4	50	10
V63X75MAF6	489353	6	10	4	75	10
V63X150MAF6	446621	6	10	4	150	10
V63X50MAF7	489343	7	13	4,5	50	10
V63X75MAF7	489354	7	13	4,5	75	10
V63X150MAF7	446622	7	13	5	150	10
V63X50MAF8	489344	8	13	5	50	10
V63X75MAF8	489355	8	13	5	75	10
V63X150MAF8	446623	8	13	5	150	10
V63X50MAF9	489345	9	14	5,5	50	10
V63X75MAF9	489356	9	14	5,5	75	10
V63X50MAF10	489346	10	16	6,5	50	10
V63X75MAF10	489357	10	16	6,5	75	10
V63X150MAF10	446624	10	16	6,5	150	10
V63X50MAF11	489347	11	17	7	50	10
V63X75MAF11	489358	11	17	7	75	10
V63X150MAF11	489369	11	17	7	100	10
V63X50MAF12	489348	12	18	7,5	50	10
V63X75MAF12	489359	12	18	7,5	75	10
V63X150MAF12	446625	12	18	7,5	150	10
V63X50MAF13	489349	13	19	8	50	10
V63X75MAF13	489360	13	19	8	75	10
V63X150MAF13	446626	13	19	8	150	10
V63X50MAF14	489350	14	20	8	50	10
V63X75MAF14	489361	14	20	8	75	10
V63X150MAF14	489372	14	20	8	100	10



VESSEL

ATTACCO 1/4" HEX - C6,3

C25

- 1/4" HEX - E6,3
- Impronta PHILLIPS
- Lama di precisione

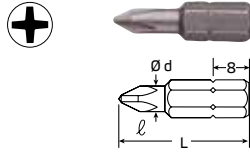

CODICE ART.	EDP No	PH	dφ	D	L	pezzi x conf.
V25N0/3	489001	0	3	H6,35	25,4	10
V25N1/4,5	489002	1	4,5	H6,35	25,4	10
V25N2/5	489003	2	5	H6,35	25,4	10

C25

- 1/4" HEX - C6,3
- Impronta PHILLIPS
- Inserto di potenza

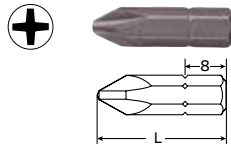

CODICE ART.	EDP No	PH	D	L	pezzi x conf.
V25N0	487100	0	H6,35	25,4	10
V25N1	487105	1	H6,35	25,4	10
V25N2	487106	2	H6,35	25,4	10
V25N3	487107	3	H6,35	25,4	10

C25

- 1/4" HEX - C6,3
- Impronta POZIDRIV
- Inserto di potenza

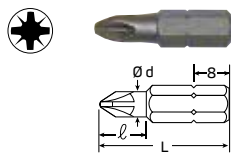

CODICE ART.	EDP No	PH	dφ	D	L	pezzi x conf.
V25P0/3	447344	0	3	H6,35	25,4	10
V25P1	487115	1		H6,35	25,4	10
V25P2	487116	2		H6,35	25,4	10
V25P3	487117	3		H6,35	25,4	10

C25

- 1/4" HEX - C6,3
- Impronta BRUGOLA
- Inserto di precisione

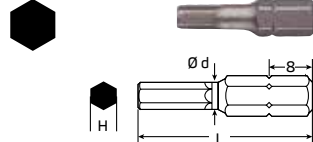

CODICE ART.	EDP No	H	D	L	pezzi x conf.
V25H1,5	489050	1,5	H6,35	25,4	10
V25H2	489051	2	H6,35	25,4	10
V25H2,5	489052	2,5	H6,35	25,4	10
V25H3	489053	3	H6,35	25,4	10
V25H4	489054	4	H6,35	25,4	10
V25H5	489055	5	H6,35	25,4	10
V25H6	489056	6	H6,35	25,4	10
V25H7	447346	7	H6,35	25,4	10
V25H8	489057	8	H6,35	25,4	10

C25

- 1/4" HEX - C6,3
- Impronta TAGLIO
- Inserto di precisione

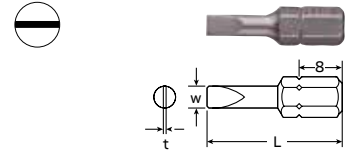

CODICE ART.	EDP No	W	t	D	L	pezzi x conf.
V25W3,5	489678	3,5	0,55	H6,35	25,4	10
V25W4	489062	4	0,6	H6,35	25,4	10
V25W5	489064	5	0,75	H6,35	25,4	10
V25W5,5	446389	5,5	0,8	H6,35	25,4	10

C25

- 1/4" HEX - C6,3
- Impronta TORX
- Inserto di precisione

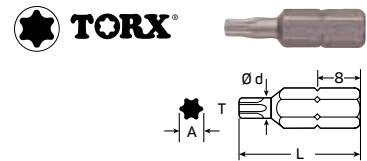

CODICE ART.	EDP No	T	A	D	L	pezzi x conf.
V25T5	489155	T5	1,37	H6,35	25,4	10
V25T6	489156	T6	1,65	H6,35	25,4	10
V25T7	489157	T7	1,99	H6,35	25,4	10
V25T8	489158	T8	2,31	H6,35	25,4	10
V25T9	489159	T9	2,5	H6,35	25,4	10
V25T10	489160	T10	2,74	H6,35	25,4	10
V25T15	489161	T15	3,27	H6,35	25,4	10
V25T20	489162	T20	3,86	H6,35	25,4	10
V25T25	489163	T25	4,43	H6,35	25,4	10
V25T27	489164	T27	4,99	H6,35	25,4	10
V25T30	489165	T30	5,52	H6,35	25,4	10
V25T40	489166	T40	6,3	H6,35	25,4	10

C25

- 1/4" HEX - C6,3
- Impronta TORX/FORO
- Inserto di precisione



CODICE ART.	EDP No	T	A	D	L	pezzi x conf.
V25TH8	446392	T8H	2,31	H6,35	25,4	10
V25TH9	446393	T9H	2,5	H6,35	25,4	10
V25TH10	489167	T10H	2,74	H6,35	25,4	10
V25TH15	489168	T15H	3,27	H6,35	25,4	10
V25TH20	489169	T20H	3,86	H6,35	25,4	10
V25TH25	489170	T25H	4,43	H6,35	25,4	10
V25TH27	489171	T27H	4,99	H6,35	25,4	10
V25TH30	489172	T30H	5,52	H6,35	25,4	10

C25

- 1/4" HEX - C6,3
- Impronta TORX PLUS
- Inserto di precisione

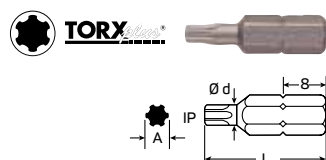

CODICE ART.	EDP No	IP	A	D	L	pezzi x conf.
V25IP6	447201	6IP	1,64	H6,35	25,4	10
V25IP8	447202	8IP	2,31	H6,35	25,4	10
V25IP10	447203	10IP	2,72	H6,35	25,4	10
V25IP15	447204	15IP	3,25	H6,35	25,4	10
V25IP20	447205	20IP	3,84	H6,35	25,4	10
V25IP25	447206	25IP	4,39	H6,35	25,4	10
V25IP30	447207	30IP	5,49	H6,35	25,4	10
V25IP40	447208	40IP	6,3	H6,35	25,4	10

C25

- 1/4" HEX - C6,3
- Impronta QUADRA
- Inserto di potenza

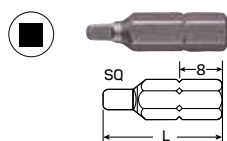

CODICE ART.	EDP No	SQ	D	L	pezzi x conf.
V25SQ1	487150	1 (3/32")	H6,35	25,4	10
V25SQ2	487151	2 (1/8")	H6,35	25,4	10
V25SQ3	487152	3 (9/64")	H6,35	25,4	10

PORTA BIT

MBC

- 1/4" HEX - E6,3
- Per 1/4"HEX C6,3
- MAGNETICO



CODICE ART.	EDP No	D	L	pezzi x conf.
V63X70MBC	486345	17	MAGNETICO	71 1

MBC

- 1/4" HEX - E6,3
- Per 1/4"HEX C6,3
- MAGNETICO



CODICE ART.	EDP No	D	L	pezzi x conf.
V63X60MDBH	482434	14,5	MAGNETICO	62 1

MBH

- 1/4" HEX - E6,3
- Per 1/4"HEX C6,3
- MAGNETICO



CODICE ART.	EDP No	D	L	pezzi x conf.
V63X75MBH2	489199	11,1	MAGNETICO	75 1
V63X100MBH2	487371	11,1	MAGNETICO	100 1
V63X150MBH2	487372	11,1	MAGNETICO	150 1

BH

- D71 MEZZALUNA
- Per 1/4"HEX C6,3
- MAGNETICO



CODICE ART.	EDP No	D	L	pezzi x conf.
V71X75MBH	447421	11,1	D71 adattatore magnetico	75 1

C25

- 1/4" HEX - C6,3
- Imp. BRUGOLA SFERICA
- Inserto di precisione

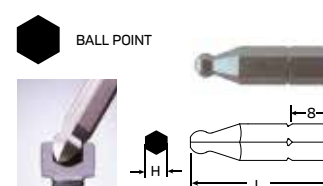

CODICE ART.	EDP No	SH	D	L	pezzi x conf.
V25SH2	446402	2	H6,35	25,4	10
V25SH2,5	446403	2,5	H6,35	25,4	10
V25SH3	446404	3	H6,35	25,4	10
V25SH4	446405	4	H6,35	25,4	10
V25SH5	446406	5	H6,35	25,4	10
V25SH6	446407	6	H6,35	25,4	10
V25SH8	446408	8	H6,35	25,4	10

C25

- 1/4" HEX - C6,3
- Impronta 3 WING
- Inserto di potenza

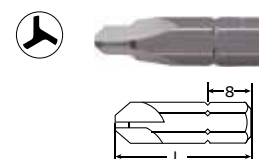

CODICE ART.	EDP No	TW	D	L	pezzi x conf.
V25TW1	446411	TW1	H6,35	25,4	10
V25TW2	446412	TW2	H6,35	25,4	10
V25TW3	446413	TW3	H6,35	25,4	10
V25TW4	446414	TW4	H6,35	25,4	10

BH

- 1/4" HEX - E6,3
- Per MMBC C6,3



CODICE ART.	EDP No	PH	I	L	pezzi x conf.
V63X60DBH	482432	14,5		62	1

BH

- 1/4" HEX - E6,3
- Per 1/4"HEX C6,3
- MAGNETICO



CODICE ART.	EDP No	D	L	pezzi x conf.
V63X60MBH	482431	11,1	MAGNETICO	60 1
V63X100MBH	487366	11,1	MAGNETICO	100 1
V63X150MBH	487367	11,1	MAGNETICO	150 1

BH

- 1/4" HEX - E6,3
- Per D71 MEZZALUNA



CODICE ART.	EDP No	D	L	pezzi x conf.
V63X45BHD71	482430	6,35	41,5	1



INSERTI FILETTATI

TB

- Inserto filettato
- Impronta PHILLIPS
- Lama di precisione
- Filettatura M4

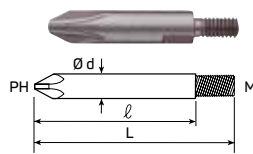

CODICE ART.	EDP No	PH	d xl	D	L	pezzi x conf.
V61M4X34N1	489656	1	6	34	10	
V61M4X34N2	489657	2	6	34	10	

TB

- Inserto filettato
- Impronta PHILLIPS
- Lama di precisione
- Filettatura M5

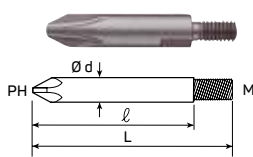

CODICE ART.	EDP No	PH	d xl	D	L	pezzi x conf.
V61M5X45N1C	PBEXP-3037	1	5x20	7	45	10
V61M5/6X45N1	489666	1	6	45	10	
V61M5X45N2C	PBEXP-3038	2	5x20	7	45	10
V61M5/6X34N2	489663	2	6	34	10	

TBD

- 1/4" HEX - E6,3
- Stelo filettato
- Alloggiamento M5



CODICE ART.	EDP No	M	D	L	pezzi x conf.
V35X65TBM5	PBEXP-3052	M5	7	65	10
V35X85TBM5	PBEXP-3053	M5	7	85	10
V35X100TBM5	PBEXP-3054	M5	7	100	10
V35X115TBM5	PBEXP-3055	M5	7	115	10
V35X145TBM5	PBEXP-3056	M5	7	145	10
V35X200TBM5NT	PBEXP-3057	M5	7 non temperato	200	10
V35X300TBM5NT	PBEXP-3058	M5	7 non temperato	300	10
V35X400TBM5NT	PBEXP-3080	M5	7 non temperato	400	10

TB

- Inserto filettato
- Impronta POZIDRIV
- Lama di precisione
- Filettatura M4

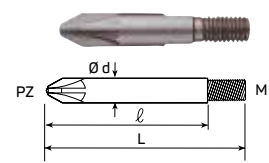

CODICE ART.	EDP No	PZ	d xl	D	L	pezzi x conf.
V61M4X34P1	489658	1	6	34	10	
V61M4X34P2	489659	2	6	34	10	

TB

- Inserto filettato
- Impronta POZIDRIV
- Lama di precisione
- Filettatura M5

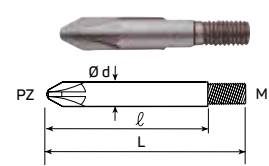

CODICE ART.	EDP No	PZ	d xl	D	L	pezzi x conf.
V61M5X45P1C	PBEXP-3039	1	5x20	7	45	10
V61M5/6X34P2	489665	2	6	34	10	
V61M5X45P2C	PBEXP-3040	2	5x20	7	45	10

A richiesta altre impronte

IB11PO1E

BITS

- Set 11 Bit con sfera
- Bit magnetici
- Include porta Bit 1/4" HEX

IB11PO1E



MAGNETIZZATORI PER LAME

- Può essere utilizzato con punte o cacciaviti fino a $\varnothing 4\text{mm}$;
- Magnetizza fortemente la punta o il cacciavite;
- Anche le filettature lunghe e grosse vengono mantenute con i forti magneti;
- La forza magnetica rimane anche dopo che il prodotto è stato tolto dalla punta;
- Può magnetizzare e smagnetizzare;
- Smagnetizza la punta o il cacciavite per evitare l'adesione dei trucioli da taglio.

MODELLO	Lunghezza	Peso	Interno C/T	Esterno C/T	N. EDP
NMS-2PR	mm 21	g 6	10	60	486779

MODELLO	Ø Interno	Ø Esterno	Altezza
AM/14	mm 7	mm 17,5	mm 10
AM5	mm 6	mm 17,5	mm 10



PISTOLE DI SOFFIAGGIO PER ARIA COMPRESSA

- AD-4: brevetto VESSEL
- Corpo in alluminio pressofuso dalle marcate proprietà di robustezza e leggerezza
- Ampia scelta di ugelli intercambiabili, lunghi, extralunghi, flessibili, ecc.
- Scudo protettivo in plastica per evitare l'allentamento accidentale della leva
- Design ergonomico
- Doppio ingresso aria (superiore/inferiore)
- Idoneo per impieghi di soffiatura e asciugatura.



CODICE	EDP	Ugello / lungh. / tipo	Assorbim. aria l/min	Peso gr	Pressione max impiego MPa	Temper. di esercizio °C	Ingresso aria	Tubo aria in ingresso mm	Conf.
AD4-N	141180	Standard, intercambiabile	180	245	0,7	0-60	Doppio rc 1/4"	> 4	10
AD4-J	141183	Con regolazione flusso, intercambiabile	150	245	0,7	0-60	Doppio rc 1/4"	> 4	10
AD4-B	141186	Con spazzola, intercambiabile	180	245	0,7	0-60	Doppio rc 1/4"	> 4	10
AD4-M	141187	Alto flusso, intercambiabile	240	245	0,7	0-60	Doppio rc 1/4"	> 4	10



ACCESSORI

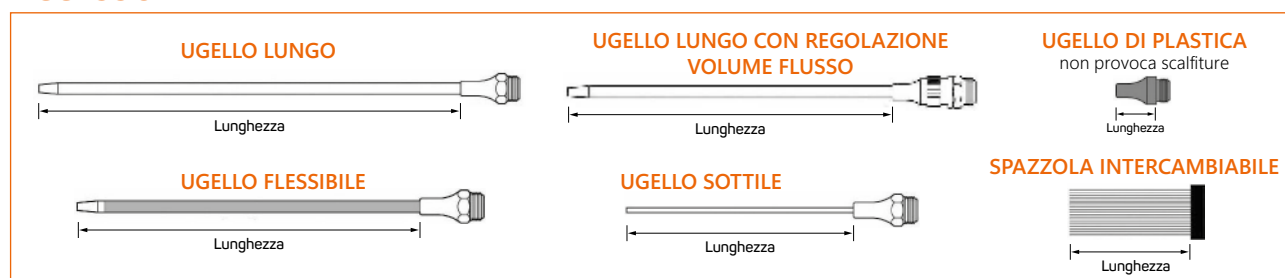

CODICE	EDP	Descrizione	Ø interno mm	Ø esterno mm	Lunghezza	Confezione
SN-0	141130	Ugello standard	-	-	-	10
SJ-0	141131	Ugello con regolazione volume flusso	-	-	-	10
SP-0	141132	Ugello in plastica di sicurezza	2	7,5	21	10
LN-150	141133	Ugello lungo 150 mm	2,5	5	150	10
LN-200	141134	Ugello lungo 200 mm	2,5	5	200	10
LN-300	141135	Ugello lungo 300 mm	2,5	5	300	10
LN-500	141136	Ugello lungo 500 mm	2,5	5	500	10
LJ-150	141137	Ugello lungo 150 mm con regolazione volume flusso	2,5	5	150	10
LJ-200	141138	Ugello lungo 200 mm con regolazione volume flusso	2,5	5	200	10
LJ-300	141139	Ugello lungo 300 mm con regolazione volume flusso	2,5	5	300	10
LJ-500	141140	Ugello lungo 500 mm con regolazione volume flusso	2,5	5	500	10
LS-2-100	141141	Ugello sottile	0,9	2	100	10
LS-3-100	141142	Ugello sottile	1,6	3	100	10
LF-150	141143	Ugello flessibile 150 mm	2,3	7	150	10
LF-200	141144	Ugello flessibile 200 mm	2,3	7	200	10
LF-300	141145	Ugello flessibile 300 mm	2,3	7	300	10
LF-700	141146	Ugello flessibile 700 mm	2,3	7	700	10
SB-50	141147	Spazzola intercambiabile	-	35	68	5
SPM-0	141148	Ugello alto flusso	-	-	-	10



PISTOLE DI SOFFIAGGIO

- Flusso non bloccabile
- Antigraffio
- Silenzioso basso valore di rumorosità
- Conforme alle norme vigenti Europee, Certificato Osha e Suvapro
- Tubo in acciaio inox AISI304
- Design ergonomico in polimero bicomponente morbido al tatto
- Attacco filettato in Ottone



PS55

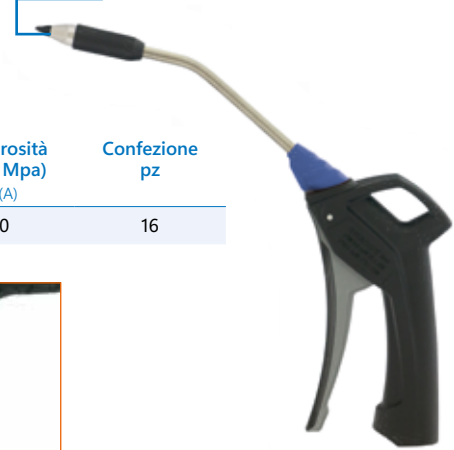

CODICE	Pressione di esercizio Mpa	Portata (a 0.6 Mpa) l/min	Peso gr	Lunghezza totale mm	Rumorosità (a 0.6 Mpa) dB(A)	Confezione pz
PS55	0,35-0,6	263	143	152	80	16

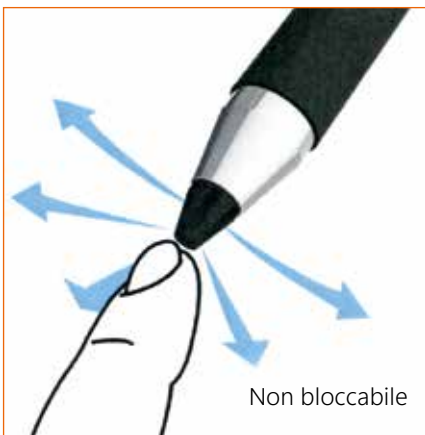

ACCESSORI AIR MARTIN

PER SCOPRIRE TUTTA LA LINEA AIRMARTIN CONSULTA IL CATALOGO DEDICATO



IDPRO-W2300

RISCALDATORE PER INDUZIONE

- Riscaldamento elettronico per induzione veloce e di grande precisione comandato da microprocessore
- Non genera fiamme
- Impiego con una sola mano
- Tempo e Potenza regolabili
- Cambio rapido spirali
- Costruito con materiali antirivolo
- Disegnato, brevettato e fabbricato in Olanda

iDUCTOR di IDTOOLS è l'attrezzo super pratico che, attraverso la tecnologia per induzione elettromagnetica, riscalda in modo circostanziato dadi, mozzi, cuscinetti o altri oggetti metallici.

Il riscaldamento per induzione induce il calore esclusivamente alla parte trattata (a differenza dei riscaldatori a fiamma); in poche decine di secondi si riesce a elevare la temperatura della parte trattata tra i 300 e i 600°C.

IDPRO-W2300 viene fornito con 2 set di spirali preformate con misure metriche da M8 e da M10 e un cavo flessibile avvolgente di 250cm.

L'accessorio a richiesta ID-PAD1515 ha il compito di riscaldare e scollare strati adesivi sulle superfici piane.

Ulteriori spirali con dimensioni fino a M30 a richiesta.

CODICE	Tensione V	Potenza W	Sicurezza	Temp. esercizio	Umidità	Protezione
ID-PRO-W2300	230	2300	Classe I	-5 - +40°C	0-90% senza consensa	IP20

Accessori a richiesta

IDC-COILKIT: M10-M12-M16-M20-M24-M30



